

XCMG FOR YOUR SUCCESS

XLC250

CRAWLER CRANE



Add: No.19 Taoshan Road, Economic development zone of jinshanqiao,Xuzhou,Jiangsu Province,China

Postal Code: 221004

Unified service hotline: 86 400-110-9999

Sales Hotline

Sale Tel: 86 0516-87892094

Sale Fax: 86 0516-87892074

E-mail: jjyxd@xcmg.com

Quality Supervision Tel: 86 0516-87892587

Service Hotline

Service Tel: 86 400-001-5678

Service Fax: 86 0516-87892080

Service Tel: 86 0516-87892086

Service Fax: 86 0516-87892083



Welcome to Xuzhou Industry and Commerce City
One-stop shop for worry-free and money-saving



Welcome to follow XCMG crawler crane official WeChat
1. Direct number "XCMG" to add friends.
2. Find the public account "Xuzhou Crawler Crane".
3. Directly scan the QR code above.

—January 2021 edition—

Note: Due to the need for continuous product improvement, we reserve the right to make changes to product models, parameters, and configurations without prior notice.



CONTENTS

P03

- PRODUCT OVERVIEW
- SAFETY PROTECTION MEASURES
- MAIN TECHNICAL PARAMETERS

P10

- 1.Heavy duty boom working condition
- Characteristics of main boom main hook under main boom working condition without boom single pulley (HB/1)
- 1.2 Characteristics of main boom main hook under main boom working condition with boom single pulley (HBS/1)
- 1.3 Characteristics of boom single pulley auxiliary hook under main boom working condition with main boom main hook (HBS/2)
- 2.Tower jib working condition
- A. Main boom working angle is 85°
- B. Main boom working angle is 75°
- C.Main boom working angle is 65°

02

XLC250 CRAWLER CRANE

P03-P05 PRODUCT OVERVIEW

P06-P06 SAFETY PROTECTION MEASURES

P08-P08 MAIN TECHNICAL PARAMETERS

PRODUCT OVERVIEW

Boom combinations

XLC250 crawler crane boom and jib are the chord and lacing member of large cross-section, thick-walled large diameter, high-strength seamless steel pipe, supplemented by high-strength steel welded into the middle of sub-section, tapered cross-section at both ends of the four chord space lattice structure.

Under heavy duty boom working condition, the Max. lifting load is 250@4.5m (18 parts of line), the Max. lifting moment is 177t×7m=1239t.m. main boom length is 17m~83m, boom composition: boom butt 1×6m, transition section 1×6m, top section: 1×5m, insert section 1×3mA and 1×3mB, insert section 1×6mA and 1×6mB, insert section 2×12mA and 2×12mB. Boom can be equipped with boom single pulley.

Under tower jib working condition, the Max. lifting load is 80t@10m (6 parts of line), tower jib length is 18m~63m, boom composition: boom butt 1×1.5m, transition section 1×4.5m, top section 1×3m, insert section 1×3mB and 1×3mC, insert section 1×6mB and 1×6mC, insert section 1×12mB and 2×12mC, front strut 1×5.8m, rear strut 1×5.5m. tower jib can be equipped with tower jib single pulley.

The length of light duty boom is 19.5m~88.5m, composed of boom sections and tower jib sections.

Under fixed jib working condition, the Max. lifting load is 75t@7m (6 parts of line). Fixed jib length is 9m~30m, jib composition: jib butt 1×1.5m, transition section 1×4.5m, jib top 1×3m, insert section 1×3mB and 1×3mC, insert section 1×6mB and 1×6mC, insert section 1×12mB, strut 1×5.8m. in which 9m fixed jib can form TBM working condition together with heavy duty boom 17m section and 20m section to be used, the Max. lifting load alone by main hook is 200t, the Max. lifting load alone by auxiliary hook is 67.6t, the Max. lifting load for the two hooks combined alternate lifting is 112.8t.

Boom luffing components

Boom luffing component is made of high-strength pendant structure with high safety factor. Pendant transition with balance beam can efficiently bear the load of two-group pendant for equal force distribution. Single pendant with "Peach"-shaped connection holes, easy assembly, saving labor and high efficient.

Mast

Mast is a box-type two-limb structure, with strengthened beam between two limbs for good stability. Mast lifting cylinder can rotate around the cylinder center and turntable connection pivot, to realize mast erection raising and lowering.

Turntable

Turntable is a key load bearing structural component to connect crane superstructure and crane undercarriage, use of high-strength steel plate welded in "工" box-type composite box beam structure on both sides, through the slewing ring coupled with undercarriage, with good overall strength and stability. Cab, main luffing winch, engine system, main pump, hydraulic valve, cabinet, mast, boom base section, superstructure counterweight and self-assembly/disassembly jacking cylinder can be respectively connected with different parts of the turntable.

Mechanism composition

Crane mechanism configuration:

No.	Name	Application	Location
1	Main hoist winch	For heavy duty boom, heavy duty boom with single pulley, fixed jib (With TBM function), tower jib, tower jib with front jib single pulley, light duty boom working conditions, used as main hook winch.	boom butt close to the root
2	Auxiliary hoist winch	[1] heavy duty boom with boom single pulley and fixed jib (with TBM) working condition, used as auxiliary winch. [2] tower jib luffing (with single pulley) working condition, used as tower jib luffing winch.	Boom butt close to the upper part
3	Single pulley hoisting unit (optional)	Tower jib front single pulley working condition, used as auxiliary winch.	Turntable front side
4	Main luffing winch	Boom luffing	Turntable middle side
5	Slewing unit	Superstructure slewing	Turntable front side
6	Travel unit	Overall crane travelling	Crawler track drive roller

The main hoisting mechanism and the auxiliary hoisting mechanism can realize joint lifting of the main hook and the auxiliary hook under the shielding working condition.

Hoist winch

Hoist winch includes main hoist winch, auxiliary hoist winch and single pulley hoist mechanism (optional), hoist winch consists of planetary reducer driven by variable motor, through drum, guide pulley and hoist pulley block to achieve main or auxiliary hook block hoisting up/down.

The planetary reducer is built in the hoisting mechanism, and the normally closed brake is adopted to realize the function of "spring brake / hydraulic release", which is safe and reliable. The hoist drum is made of ductile iron with double line multilayer winding, with good vibration absorption, to ensure rope rotation-resistance for multilayer rope winding, effectively increasing the wire rope service life.

The hoisting mechanism uses independent steel core, high breaking force, high extrusion resistance of anti-rotation special steel wire rope, rated single rope.

Tensile force 14.3t, wire rope diameter ϕ 26mm, the length of main, auxiliary and single pulley lifting ropes are 455m, 290m and 250m respectively.

Luffing mechanism

The luffing mechanism includes main luffing mechanism and tower jib luffing mechanism. The main luffing mechanism is independently driven by the double drum and is installed in the middle of the turntable through the pin shaft.

The main luffing mechanism is a planetary gear reducer driven by a motor, and the luffing of the main boom is realized through the drum and the luffing pulley block. The main luffing mechanism is equipped with a planetary reducer and a normally closed brake to realize the function of "spring braking / hydraulic release", which is safe and reliable.

The luffing drum has a ratchet lock device in which the pawl is driven by hydraulic cylinder to realize multiple protection.

The main luffing drum is made of ductile iron with double line multilayer winding, with good vibration absorption, to ensure rope rotation-resistance for multilayer rope winding, effectively increasing the wire rope service life.

The main luffing mechanism uses steel wire rope with high breaking force, the rated single line pull is 10.8t, and the diameter of steel wire rope ϕ 26mm, 275m in length.

The luffing mechanism and the auxiliary hoisting mechanism are the same device, installed on boom butt, tower jib luffing is realized through function switching.

Slewing Mechanism

The slewing mechanism and slewing bearing is outer meshed driven, it is placed in the front of the inner side of turntable, it is the motor drive the planetary gear reducer and slewing bearing to realize 360° slewing.

There is a planetary reducer inside the slewing mechanism which adopted constant closed brake to realize "spring brake/hydraulic release" function, it is reliable and safe.

Slewing mechanism is set with slewing lock device to realize the locking protection to slewing mechanism.

The slewing mechanism has free sliding function.

Slewing bearing

The 3-row roller type straight tooth external meshing slewing bearing or elliptical raceway double row ball slewing bearing is adopted, with high strength, large bearing moment, high precision, long service life and convenient maintenance.

Cylinder assembly

The connection of boom and turntable, car-body and crawler track, counterweight tray and turntable, are all power-pin connected driven by cylinder. The mast raising cylinder, outrigger cylinder, crawler track tightening cylinder make the assembly and dismantling more convenient; the cab cylinder helps vertical turning-over and horizontal turning-over of cab.

Operator's cab

The leopard head type control room designed on the principle of ergonomics has gorgeous appearance, wide field of vision, comfortable and convenient operation.

Car-body

The car-body is a box-type radial structure, which is welded by high-strength steel plate, and has good overall rigidity and high strength.

Crawler track travel device

There are two crawler tracks, each of the two is composed of track beam, track shoe, bearing roller, a driving roller, a guiding roller, an upper roller, and a tensioning device.

Crawler track: Symmetrically placed both at left side and at right side, and with one at each side. The box-type structure welded by high-strength steel plate, the parallel iron is set at the connection position between track and car-body for guiding and wear-resistance.

Drive roller: High-strength wear-resistant alloy steel, connected to the planetary reducer housing with high-strength bolts.

Bearing roller: High-strength wear-resistant alloy steel with double flange design, built-in floating seal and self-lubricating.

Track shoes: high-strength wear-resistant alloy steel.

Travel mechanism: constantly closed planetary gear reducer with strong driving power and high flexibility and maneuverability. Multi-plate wet constantly closed brake, spring brake, hydraulic release.

Hydraulic system

Load-sensitive LUDV system with hydraulic pilot proportional control, precise speed, sensitive operation and fine movement. The main valve can realize combined operations of multiple operations, compact structure and convenient maintenance.

Special rotary closed system design, smooth start and stop, good fine-motion, good proportional characteristics, strong anti-load change interference ability, meet the requirements of fine lifting operation.

Electrical system

The electrical system mainly includes the following parts: engine control, monitoring instruments, auxiliary equipment, hydraulic system control, load moment limit and safety monitoring.

The composition of the electrical system: conventional electrical system and PLC control system.

Conventional electrical system includes power supplies, start controls, cab air conditioning and audio, lighting, wipers, and more.

The PLC control system includes the control of main and auxiliary winches, slewing, main boom luffing, engine condition monitoring, and all actions that are controlled by PLC logic of CAN-bus technology.

SAFETY PROTECTION MEASURES

Engine system

Model: WEICHAI WP10G336E344
 Type: in-line, six-cylinder, water-cooled, supercharged intercooled, four-stroke diesel engine
 Environmental protection: in line with national III standard and European III emission standard.
 Rated power: 247kw/1900rpm;
 Max. output torque: 1550N.m;

Counterweight

Counterweight is composed of car-body counterweight and turntable counterweight.
 Car-body counterweight is 21t totally, car-body counterweight can realize self-assembly/dismantling by using mast crane, car-body counterweight is installed at the front side and rear side of crawler tracks. Its composition is: car-body counterweight 2 × 10.5t.
 There are 3 kinds of turntable counterweight to choose: 75t, 65t and 55t. for different lifting needs, In the design, independent performance tables are provided according to the grading counterweight, which makes the working conditions of customers more practical, economical, convenient and fast. In addition, according to the best number of counterweights in use conditions, it can also save more transportation costs and purchase costs for customers.
 Turntable counterweight is installed at the rear side of turntable. Available counterweight composition is as the following:
 (1) Turntable counterweight 75t: counterweight tray 1 × 15t, turntable counterweight block 12 × 5t;
 (2) Turntable counterweight 65t: counterweight tray 1 × 15t, turntable counterweight block 10 × 5t;
 (3) Turntable counterweight 55t: counterweight tray 1 × 15t, turntable counterweight block 8 × 5t;

Hook

Hook block configuration is as the following:

Hook Name	80T	13.5T	160T (optional)	100T (optional)	32T (optional)
Weight (t)	0.95	0.5	2.18	1.67	0.7
Quantity	1	1	1	1	1
Pulley blocks	2	0	8	4	1

The crane uses a variety of mechanical, electronic and hydraulic safety and alarm devices to ensure the safe use. Safety devices include load moment limiter, slewing locking device, boom backstop device, lifting height limit device, boom angle limit device, anemometer, level gauge, camera, slewing warning, travel warning, hydraulic system relief valve, balance valve, hydraulic locks, etc.

Mode switch

In the installation mode, the over-reeving protection device, the boom limit device, the load moment limiter, etc. do not work, so as to facilitate the installation of the crane; in the working mode, all the safety devices work.

Emergency stop

With emergency stop function, it can quickly stop all actions in an emergency

Mis-operation protection

The handle has mis-operation protection function, and a safety protection switch is arranged on the front side of the handle. When the switch is not pressed, all the action signals are shielded, and the handle does not work to prevent mis-operation.

Over reeving protection

There is an over-reeving protection device on the boom head to prevent rope from over-reeved. When it come to a certain height, the over-reeving indicator is light, meanwhile hoisting movement stops automatically.

Over-releasing protection

For each hoisting mechanism, there is a rope end limiter to prevent the rope from voer released. When the rope is only 3 loops remained, the over-released indicator is light, meanwhile, the lowering movement automatically stops.

Ratchet lock

There is a ratchet lock device used for luffing winch locking to guarantee the safe placing of boom while non-working.

Slewing lock

The slewing and locking of superstructure when crane stops.

Backstop function

There are backstop devices on main boom and auxiliary jib to prevent boom and struts from backstop.

Boom angle limitation

When the boom is hoisted up to specified angle, the hoisting movement stops, and the load moment limiter and stroke switch provides a dual control. When boom angle is smaller than the specified angle, the lowering movement stops, it is controlled by the load moment sound warning is sent out.

Hook latch protection

Hook latch is installed to prevent the sling from slipping out from the hook.

Hydraulic system protection

Equipped with hydraulic balance valve, hydraulic relief valve and other devices to ensure the stability and safety of the system.

Load moment limiter

Detection function: the LML can automatically detect the angle and load of the boom.
 Display function: color large screen touch LCD (10.4 inches). The lifting operation parameters such as load moment percentage, actual lifting capacity, rated lifting capacity, working radius, boom length, angle, maximum lifting height, working condition code, parts of line, limiting angle and information code are displayed in Chinese (or English) and graphics.
 Warning function: it has complete pre alarm and overload stop function. If it is detected that the actual load exceeds the limit load and the boom exceeds the limit angle, the load moment limiter will give an alarm and limit the current action.
 The system has the function of fault self-diagnosis.

Audio/video warning

There are triple-color warning light and audio/video alarm provide warning to the driver and other personnel outside the cab.

Illuminating light

Illumination lights are placed in front of the turntable, above the cab and in the cab to provide illumination.

Rearview mirror

Located outside cab, it is convenient for the driver to observe the situation behind the crane.

Height indicating light

The height indicating light is installed on the top of the boom for high altitude warning.

Wind instrument

The current wind speed is detected in real time and transmitted to the monitor in the cab to alert the operator to the safety of the wind load.

Level gauge

It is equipped with a mechanical level gauge that shows the degree of inclination of the road surface used and provides the operator levelness of crane for reference.

Monitoring system

It is composed of three cameras and a monitor, which can monitor the rope arrangement of main winch, auxiliary winch and luffing winch and the safety situation of the rear of the car body.

MAIN TECHNICAL PARAMETERS



Main technical parameters

Items	Unit	Data	
Max. rated lifting load	Main boom working condition	t	250
	Tower jib working condition	t	80
	Fixed jib working condition	t	75
Max. lifting moment	t.m	1239	
Size dimension	Boom length	m	17~83
	Tower jib length (optional)	m	18~63
	Fixed jib length (optional)	m	9~30
Speed parameters	Max. single line speed of hoisting	m/min	120
	Max. single line speed of boom luffing	m/min	2×34
	Max. single line speed of tower jib luffing	m/min	120
	Max. slewing speed	rpm	1.4
Engine	Max. travel speed	km/h	1.1
	Rated power	kW	243
	Emission standard	-	National III off-road
Overall crane weight (17m basic boom, 160t hook)		t	191
Average ground pressure		MPa	0.11
Grade-ability		-	30%
Max. transport weight of single unit		t	32.9
Max. transport size of single unit (L×W×H)		m	9.9×3.0×3.3

Notes:

1. The wire rope speed refers to the calculated value of the outermost working layer of the drum when the engine is running without load, which will vary according to the load and operating conditions.
2. Travel speed, grade-ability, average ground pressure and turning speed are calculated theoretical value based on the plane, smooth and solid ground.
3. The table values are the configuration parameters based on 75t turntable counterweight and 21t car-body counterweight.
4. We reserves the right to update and change the technical parameters without prior notice.

Outline dimension

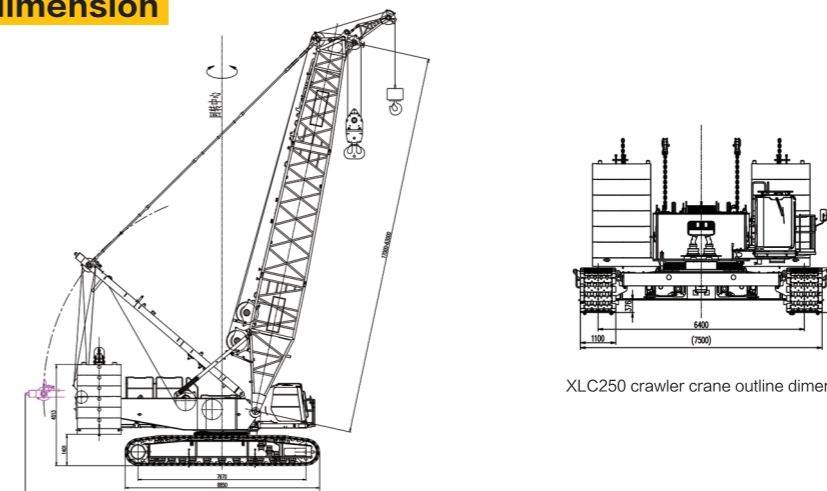

XLC250 crawler crane outline dimension

09

XLC250 CRAWLER CRANE

- P10-P13 1.Heavy duty boom working condition
- P14-P20 Characteristics of main boom main hook under main boom working condition without boom single pulley (HB/1)
- P21-P27 1.2 Characteristics of main boom main hook under main boom working condition with boom single pulley (HBS/1)
- P28-P37 1.3 Characteristics of boom single pulley auxiliary hook under main boom working condition with main boom main hook (HBS/2)
- P38-P38 2.Tower jib working condition
- P39-P44 A. Main boom working angle is 85°
- P45-P50 B. Main boom working angle is 75°
- P51-P56 C.Main boom working angle is 65°

TYPICAL WORKING CONDITIONS

Heavy duty boom working condition

A. heavy duty boom sections combination table without boom head single pulley

Name and qty. Main boom combination	Boom Butt 6m	Main boom Insert section 3mA	Main boom Insert section 6mA	Main boom Insert section 12mA	Boom transition section 6m	Main boom Insert section 3mB	Main boom Insert section 6mB	Main boom Insert section 12mB	Boom top 5m
HB17	1	0	0	0	1	0	0	0	1
HB20	1	1	0	0	1	0	0	0	1
HB23	1	0	1	0	1	0	0	0	1
HB26	1	1	1	0	1	0	0	0	1
HB29	1	0	0	1	1	0	0	0	1
HB32	1	1	0	1	1	0	0	0	1
HB35	1	0	1	1	1	0	0	0	1
HB38	1	1	1	1	1	0	0	0	1
HB41	1	0	0	2	1	0	0	0	1
HB44	1	1	0	2	1	0	0	0	1
HB47	1	0	1	2	1	0	0	0	1
HB50	1	1	1	2	1	0	0	0	1
HB53	1	0	0	2	1	0	0	1	1
HB56	1	1	0	2	1	0	0	1	1
HB59	1	0	1	2	1	0	0	1	1
HB62	1	1	1	2	1	0	0	1	1
HB65	1	1	1	2	1	1	0	1	1
HB68	1	1	1	2	1	0	1	1	1
*HB71	1	1	1	2	1	1	1	1	1
*HB74	1	1	1	2	1	0	0	2	1
*HB77	1	1	1	2	1	1	0	2	1
*HB80	1	1	1	2	1	0	1	2	1
*HB83	1	1	1	2	1	1	1	2	1

Notes:

1. Center hitch must be used for data with “*” .
2. Tower jib rear pendants must be removed for boom section; the tower jib guide pulley must be removed for the boom top section.

TYPICAL WORKING CONDITIONS

B. Boom sections combinations with boom single pulley

Name and qty. Main boom combination	Boom Butt 6m	Main boom Insert section 3mA	Main boom Insert section 6mA	Main boom Insert section 12mA	Boom transition section 6m	Main boom Insert section 3mB	Main boom Insert section 6mB	Main boom Insert section 12mB	Boom top 5m
HBS17	1	0	0	0	1	0	0	0	1
HBS20	1	1	0	0	1	0	0	0	1
HBS23	1	0	1	0	1	0	0	0	1
HBS26	1	1	1	0	1	0	0	0	1
HBS29	1	0	0	1	1	0	0	0	1
HBS32	1	1	0	1	1	0	0	0	1
HBS35	1	0	1	1	1	0	0	0	1
HBS38	1	1	1	1	1	0	0	0	1
HBS41	1	0	0	2	1	0	0	0	1
HBS44	1	1	0	2	1	0	0	0	1
HBS47	1	0	1	2	1	0	0	0	1
HBS50	1	1	1	2	1	0	0	0	1
HBS53	1	0	0	2	1	0	0	1	1
HBS56	1	1	0	2	1	0	0	1	1
HBS59	1	0	1	2	1	0	0	1	1
HBS62	1	1	1	2	1	0	0	1	1
HBS65	1	1	1	2	1	1	0	1	1
HBS68	1	1	1	2	1	0	1	1	1
*HBS71	1	1	1	2	1	1	1	1	1
*HBS74	1	1	1	2	1	0	0	2	1
*HBS77	1	1	1	2	1	1	0	2	1
*HBS80	1	1	1	2	1	0	1	2	1
*HBS83	1	1	1	2	1	1	1	2	1

Notes:

- center hitch must be used for data with “*” .
- tower jib rear pendants must be removed for boom section, the tower jib guide pulley must be removed for the boom top section.

C. Boom raising table under main boom working condition

Boom raising table under main boom working condition without boom single pulley (HB/1)

HB/1	Counterweight combination: Turntable counterweight (t)+Car-body counterweight (t)		
Main boom combination	75+21	65+21	55+21
HB17	○	○	○
HB20	○	○	○
HB23	○	○	○
HB26	○	○	○
HB29	○	○	○
HB32	○	○	○
HB35	○	○	○
HB38	○	○	○
HB41	○	○	○
HB44	○	○	○
HB47	○	○	○
HB50	○	○	○
HB53	○	○	○
HB56	○	○	○
HB59	○	○	○
HB62	○	○	○
HB65	○	○	○
HB68	○	○	○
*HB71	○	○	○
*HB74	○	○	○
*HB77	○	○	○
*HB80	○	○	●
*HB83	○	●	x

Notes:

- “○” - boom can be raised; “●” -- wedge required to raise boom; “x” - boom cannot be raised, this working condition cannot be used.
- “*” Boom length needs to use center hitch.
- When boom raising, place crawler drive roller at the rear of the crane.

TYPICAL WORKING CONDITIONS

C. Boom raising table under main boom working condition

Boom raising table under boom working condition with boom single pulley (HBS/1 & HBS/2)

HBS/1 & HBS/2	Counterweight combination: Turntable counterweight (t)+Car-body counterweight (t)		
	75+21	65+21	55+21
Main boom combination			
HB17	○	○	○
HB20	○	○	○
HB23	○	○	○
HB26	○	○	○
HB29	○	○	○
HB32	○	○	○
HB35	○	○	○
HB38	○	○	○
HB41	○	○	○
HB44	○	○	○
HB47	○	○	○
HB50	○	○	○
HB53	○	○	○
HB56	○	○	○
HB59	○	○	○
HB62	○	○	○
HB65	○	○	○
HB68	○	○	○
*HB71	○	○	○
*HB74	○	○	●
*HB77	○	○	×
*HB80	○	●	×
*HB83	○	×	×

- Notes:
1. "○" - boom can be raised; "●" -- wedge required to raise boom; "×" - boom cannot be raised, this working condition cannot be used.
 2. "*" Boom length needs to use 1.33m center hitch.
 3. For boom raising, position crawler drive sprocket at the rear of the crane.

1.1 Characteristics of main boom main hook under main boom working condition without boom single pulley (HB/1)

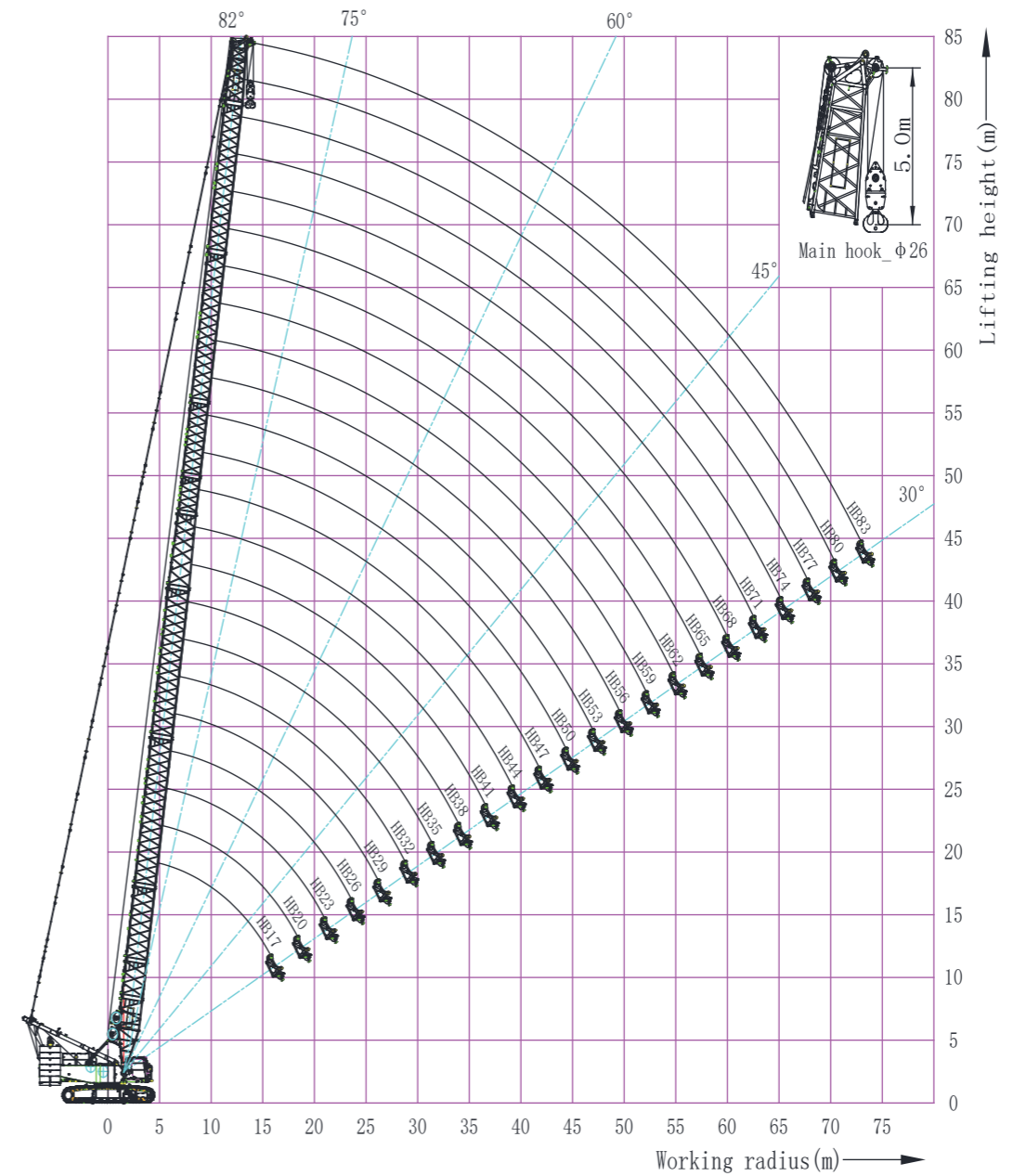

Working range of main boom main hook under main boom working condition without boom single pulley (HB/1)

TYPICAL WORKING CONDITIONS

Performance of main boom main hook under main boom working condition without boom single pulley (HB/1_75t+21t)

Working radius (m)	Main boom length (m)											
	17	20	23	26	29	32	35	38	41	44	47	50
4.5	250.0											
5	220.0											
6	196.0	195.5	193.5	179.5								
7	177.0	176.0	174.5	173.5	167.9	156.1	144.2					
8	154.5	154.0	153.5	151.9	147.3	144.7	138.2	127.2	115.3	111.2		
9	136.8	136.0	135.2	133.4	132.5	129.2	126.0	122.9	115.3	111.2	107.2	
10	116.7	117.1	117.4	117.5	116.6	114.0	111.4	108.9	106.5	103.2	102.0	99.8
12	88.6	89.1	89.3	89.4	89.5	89.5	89.5	88.4	86.7	85.1	83.4	81.9
14	70.9	71.3	71.6	71.7	71.8	71.8	71.7	71.7	71.6	71.5	70.3	69.1
16	58.5	59.1	59.4	59.5	59.6	59.6	59.5	59.4	59.3	59.2	59.1	59.0
18		50.1	50.4	50.6	50.6	50.6	50.6	50.5	50.4	50.3	50.1	50.0
20			43.6	43.7	43.8	43.8	43.8	43.7	43.6	43.4	43.3	43.2
22				38.3	38.4	38.4	38.4	38.3	38.2	38.1	37.9	37.8
24				33.9	34.0	34.1	34.0	33.9	33.8	33.7	33.6	33.4
26					30.4	30.4	30.4	30.3	30.2	30.1	30.0	29.8
28						27.4	27.4	27.3	27.2	27.1	26.9	26.8
30							24.8	24.7	24.6	24.5	24.4	24.2
32							22.5	22.5	22.4	22.3	22.1	22.0
34								20.5	20.4	20.3	20.2	20.0
36									18.8	18.6	18.5	18.3
38										17.2	17.1	16.9
40										15.7	15.6	15.4
42											14.4	14.2
44												13.1
Parts of line	18	18	16	14	13	12	11	10	9	9	8	8

- Notes:
1. The actual weight of hook, sling, and rope on hook and boom head must be deducted from the rated lifting capacity in the table.
 2. The rated lifting capacity in the table is the value of the crane on level and solid ground, slowly lifting a load and without travel.
 3. The rated lifting capacity in the table is the calculation value based on the boom sections without tower jib rear pendant, tower jib guide pulley and boom single top.
 4. Tower jib rear pendant need to be removed from boom sections, tower jib guide pulley need to be removed from boom top.
 5. Boom length exceeds 71m with “**”, center hitch must be used; boom length exceeds 74m, a wedge block must be used for boom raising.

Performance of main boom main hook under main boom working condition without boom single pulley (HB/1_75t+21t) (continuous table)

Working radius (m)	Main boom length (m)											
	53	56	59	62	65	68	71*	74*	77*	80*	83*	
10	94.5	81.6	81.6	81.1								
12	80.6	79.2	77.7	76.2	73.1	64.1	60.3	55.1				
14	68.2	67.0	65.9	64.7	63.6	62.5	58.5	53.5	48.8	44.7	40.9	
16	58.8	57.9	56.9	55.9	55.0	54.2	53.2	52.0	47.4	43.4	39.7	
18	50.1	50.0	49.8	49.0	48.3	47.6	46.7	46.1	45.3	42.1	38.6	
20	43.3	43.1	43.0	42.8	42.6	42.2	41.4	40.9	40.2	39.7	37.4	
22	37.9	37.7	37.6	37.4	37.2	37.1	36.8	36.6	36.0	35.5	34.8	
24	33.5	33.4	33.2	33.0	32.8	32.7	32.4	32.4	32.2	31.9	31.4	
26	29.9	29.8	29.6	29.4	29.2	29.1	28.8	28.8	28.6	28.5	28.2	
28	26.9	26.7	26.6	26.4	26.1	26.1	25.8	25.8	25.5	25.4	25.2	
30	24.3	24.2	24.0	23.8	23.6	23.5	23.2	23.2	22.9	22.8	22.6	
32	22.1	21.9	21.7	21.6	21.3	21.2	21.0	20.9	20.7	20.6	20.3	
34	20.2	20.0	19.8	19.6	19.4	19.3	19.0	19.0	18.8	18.6	18.4	
36	18.5	18.3	18.1	17.9	17.7	17.6	17.3	17.3	17.1	16.9	16.7	
38	17.0	16.8	16.6	16.4	16.2	16.1	15.8	15.8	15.5	15.4	15.2	
40	15.6	15.4	15.2	15.0	14.8	14.7	14.5	14.4	14.2	14.1	13.8	
42	14.4	14.2	14.0	13.8	13.6	13.5	13.2	13.2	13.0	12.9	12.6	
44	13.4	13.2	13.0	12.8	12.6	12.4	12.2	12.1	11.9	11.8	11.5	
46	12.3	12.1	11.9	11.7	11.5	11.5	11.3	11.1	10.9	10.8	10.5	
48		11.2	11.0	10.8	10.6	10.5	10.2	10.3	10.1	9.9	9.6	
50		10.3	10.2	10.0	9.8	9.7	9.4	9.5	9.3	9.1	8.9	
52			9.4	9.2	9.0	8.9	8.6	8.6	8.4	8.4	8.0	
54				8.5	8.3	8.2	7.9	7.9	7.7	7.6	7.3	
56					7.6	7.5	7.3	7.3	7.0	6.9	6.7	
58						7.0	6.9	6.7	6.7	6.4	6.1	
60							6.4	6.1	6.1	5.9	5.5	
62								5.6	5.6	5.3	5.0	
64									5.1	4.8	4.5	
66										4.4	4.0	
68										3.9	3.6	
70											3.4	3.2
Parts of line	7	6	6	6	6	5	5	4	4	4	4	

- Notes:
1. Boom length exceeds 71m with “**”, center hitch must be used; boom length exceeds 74m, a wedge block must be used for boom raising.
 2. Tower jib rear pendant need to be removed from boom sections, tower jib guide pulley need to be removed from boom top.

TYPICAL WORKING CONDITIONS

Performance of main boom main hook under main boom working condition without boom single pulley (HB/1_65t+21t)

Working radius (m)	Main boom length (m)												
	17	20	23	26	29	32	35	38	41	44	47	50	
4.5	250												
5	220												
6	196	192	193.5	179									
7	177	176	174.5	171	165	156	144						
8	152	153	148	144	140	136	132	127	115	103			
9	126	126	126	124	121	118	115	112	109	103	99		
10	106	107	107	107	106	104	101	99.5	97.3	95.2	93.1	91	
12	80.9	81.3	81.6	81.7	81.8	81.8	81.8	80.7	79.1	77.6	76.1	74.6	
14	64.6	65	65.3	65.4	65.5	65.5	65.4	65.4	65.3	65.1	64	62.8	
16	53.2	53.8	54.1	54.2	54.2	54.2	54.2	54.1	54	53.9	53.8	53.7	
18		45.5	45.8	45.9	46	46	46	45.9	45.8	45.7	45.5	45.4	
20			39.5	39.7	39.8	39.7	39.7	39.6	39.5	39.4	39.2	39.1	
22				34.7	34.8	34.8	34.7	34.6	34.5	34.4	34.3	34.1	
24				30.6	30.7	30.8	30.7	30.6	30.5	30.4	30.3	30.1	
26					27.4	27.4	27.4	27.3	27.2	27.1	26.9	26.8	
28						24.6	24.6	24.5	24.4	24.3	24.2	24	
30							22.2	22.1	22.1	21.9	21.8	21.6	
32							20.1	20.1	20	19.9	19.7	19.6	
34								18.2	18.2	18.1	17.9	17.8	
36									16.6	16.5	16.4	16.2	
38										15.1	15	14.8	
40											13.8	13.6	
42												12.6	
44													11.4
Parts of line	18	18	16	14	13	12	11	10	9	9	8	8	

Notes:
 1. Boom length exceeds 71m with “*”, center hitch must be used; boom length exceeds 74m, a wedge block must be used for boom raising.
 2. Tower jib rear pendant need to be removed from boom sections, tower jib guide pulley need to be removed from boom top.

Performance of main boom main hook under main boom working condition without boom single pulley (HB/1_65t+21t) (continuous table)

Working radius (m)	Main boom length (m)										
	53	56	59	62	65	68	71*	74*	77*	80*	83*
10	89.4	81.5	81.5	68.5							
12	73.5	72.1	70.7	68.5	68	62.6	60.2	55			
14	62	60.9	59.9	58.8	57.7	56.8	55.7	53.5	48.8	44.6	40.8
16	53.4	52.5	51.6	50.7	49.8	49.1	48.1	47.5	46.6	43.3	39.7
18	45.5	45.4	45.1	44.4	43.6	43	42.2	41.6	40.9	40.3	38.5
20	39.2	39.1	38.9	38.7	38.5	38	37.3	36.8	36.2	35.6	35
22	34.3	34.1	33.9	33.7	33.5	33.4	33.2	32.9	32.3	31.8	31.2
24	30.2	30.1	29.9	29.7	29.5	29.4	29.1	29.1	28.9	28.5	28
26	26.9	26.8	26.6	26.4	26.2	26.1	25.8	25.8	25.6	25.4	25.2
28	24.1	24	23.8	23.6	23.4	23.3	23	23	22.8	22.6	22.4
30	21.8	21.6	21.4	21.2	21	20.9	20.6	20.6	20.4	20.2	20
32	19.7	19.5	19.4	19.2	18.9	18.8	18.6	18.6	18.3	18.2	18
34	17.9	17.8	17.6	17.4	17.1	17.1	16.8	16.8	16.5	16.4	16.2
36	16.4	16.2	16	15.8	15.6	15.5	15.2	15.2	15	14.8	14.6
38	15	14.8	14.6	14.4	14.2	14.1	13.8	13.8	13.6	13.4	13.2
40	13.7	13.5	13.4	13.2	12.9	12.8	12.6	12.6	12.3	12.2	11.9
42	12.6	12.4	12.2	12	11.8	11.7	11.5	11.4	11.2	11.1	10.8
44	11.6	11.4	11.2	11	10.8	10.7	10.4	10.4	10.2	10.1	9.8
46	10.6	10.5	10.3	10.1	9.9	9.8	9.5	9.5	9.3	9.1	8.9
48		9.6	9.5	9.3	9	9	8.7	8.7	8.4	8.3	8.1
50		8.8	8.7	8.5	8.3	8.2	7.9	7.9	7.7	7.5	7.3
52			8	7.8	7.6	7.5	7.2	7.2	7	6.8	6.6
54				7.1	6.9	6.8	6.6	6.6	6.3	6.2	5.9
56					6.3	6.2	6	6	5.7	5.6	5.3
58						5.7	5.7	5.4	5.4	5.2	4.8
60							5.1	4.9	4.9	4.6	4.3
62								4.4	4.4	4.1	3.8
64									3.9	3.7	3.3
66									3.5	3.2	2.9
68										2.8	2.7
70											2.3
Parts of line	7	6	6	6	6	5	5	4	4	4	4

Notes:
 1. Boom length exceeds 71m with “*”, center hitch must be used; boom length exceeds 74m, a wedge block must be used for boom raising.
 2. Tower jib rear pendant need to be removed from boom sections, tower jib guide pulley needs to be removed from boom top.

TYPICAL WORKING CONDITIONS

Performance of main boom main hook under main boom working condition without boom single pulley (HB/1_55t+21t)

Working radius (m)	Main boom length (m)											
	17	20	23	26	29	32	35	38	41	44	47	50
5	200											
6	196	192	193.5	179								
7	170	167	161	155	150	145	140					
8	139	139	134	131	127	123	120	116	113	103		
9	114	115	115	112	109	107	104	101	99.4	97	94.7	
10	96.8	97.2	97.4	97.6	96.6	94.4	92.3	90.2	88.2	86.2	84.3	82.4
12	73.2	73.6	73.9	74	74.1	74.1	74.1	73	71.5	70.1	68.7	67.4
14	58.3	58.8	59	59.1	59.2	59.2	59.2	59.1	59	58.8	57.7	56.6
16	47.9	48.5	48.8	48.9	49	48.9	48.9	48.8	48.7	48.6	48.5	48.4
18		40.9	41.3	41.4	41.5	41.4	41.4	41.3	41.2	41.1	41	40.8
20			35.5	35.6	35.7	35.7	35.7	35.6	35.5	35.3	35.2	35.1
22				31.1	31.2	31.2	31.1	31	31	30.8	30.7	30.5
24				27.3	27.5	27.5	27.5	27.4	27.3	27.2	27	26.8
26					24.4	24.5	24.4	24.3	24.3	24.1	24	23.8
28						21.9	21.9	21.8	21.7	21.6	21.4	21.3
30							19.7	19.6	19.5	19.4	19.3	19.1
32							17.8	17.7	17.7	17.5	17.4	17.2
34								16.1	16	15.9	15.8	15.6
36									14.5	14.4	14.3	14.1
38										13.1	13	12.9
40										12	11.9	11.7
42											10.8	10.7
44												9.7
Parts of line	18	18	16	14	13	12	11	10	9	9	8	8

Notes:
 1. Boom length exceeds 71m with “*”, center hitch must be used; boom length exceeds 74m, a wedge block must be used for boom raising.
 2. 1 Tower jib rear pendant need to be removed from boom sections; tower jib guide pulley needs to be removed from boom top.

Performance of main boom main hook under main boom working condition without boom single pulley (HB/1_55t+21t) (continuous table)

Working radius (m)	Main boom length (m)									
	53	56	59	62	65	68	71*	74*	77*	80*
10	81	79.2	77.5	68.5						
12	66.4	65.1	63.8	62.6	61.3	60.3	59	55		
14	55.9	54.9	53.9	52.9	51.9	51.1	50	49.3	48.3	44.6
16	48	47.2	46.4	45.5	44.7	44	43.1	42.5	41.7	41.1
18	41	40.8	40.4	39.7	39	38.4	37.7	37.2	36.5	35.9
20	35.2	35	34.9	34.7	34.4	33.9	33.2	32.8	32.2	31.7
22	30.7	30.5	30.3	30.1	29.9	29.9	29.5	29.2	28.6	28.2
24	27	26.8	26.6	26.5	26.2	26.2	25.9	25.9	25.6	25.2
26	24	23.8	23.6	23.4	23.2	23.1	22.8	22.8	22.6	22.5
28	21.4	21.2	21.1	20.9	20.6	20.6	20.3	20.3	20	19.9
30	19.2	19.1	18.9	18.7	18.5	18.4	18.1	18.1	17.8	17.7
32	17.4	17.2	17	16.8	16.6	16.5	16.2	16.2	16	15.8
34	15.7	15.6	15.4	15.2	14.9	14.9	14.6	14.6	14.3	14.2
36	14.3	14.1	13.9	13.7	13.5	13.4	13.1	13.1	12.9	12.8
38	13	12.8	12.7	12.5	12.2	12.1	11.9	11.9	11.6	11.5
40	11.9	11.7	11.5	11.3	11.1	11	10.7	10.7	10.5	10.3
42	10.8	10.7	10.5	10.3	10.1	10	9.7	9.7	9.5	9.3
44	9.9	9.8	9.6	9.4	9.1	9.1	8.8	8.8	8.5	8.4
46	9.1	8.9	8.7	8.5	8.3	8.2	7.9	7.9	7.7	7.6
48		8.1	7.9	7.8	7.5	7.4	7.2	7.2	6.9	6.8
50		7.4	7.2	7.1	6.8	6.7	6.5	6.5	6.2	6.1
52			6.6	6.4	6.2	6.1	5.8	5.8	5.6	5.5
54				5.8	5.6	5.5	5.2	5.2	5	4.9
56					5	4.9	4.7	4.7	4.4	4.3
58					4.5	4.4	4.2	4.2	3.9	3.8
60						3.9	3.7	3.7	3.4	3.3
62							3.2	3.2	3	2.9
64								2.8	2.6	2.5
66								2.4	2.2	2.1
Parts of line	7	6	6	6	6	5	5	4	4	4

Notes:
 1. Boom length exceeds 71m with “*”, center hitch must be used; boom length exceeds 74m, a wedge block must be used for boom raising.
 2. 1 Tower jib rear pendant need to be removed from boom sections; tower jib guide pulley needs to be removed from boom top.

TYPICAL WORKING CONDITIONS

1.2 Characteristics of main boom main hook under main boom working condition with boom single pulley (HBS/1)

Working range of main boom main hook under main boom working condition with boom single pulley auxiliary hook (HBS/1)

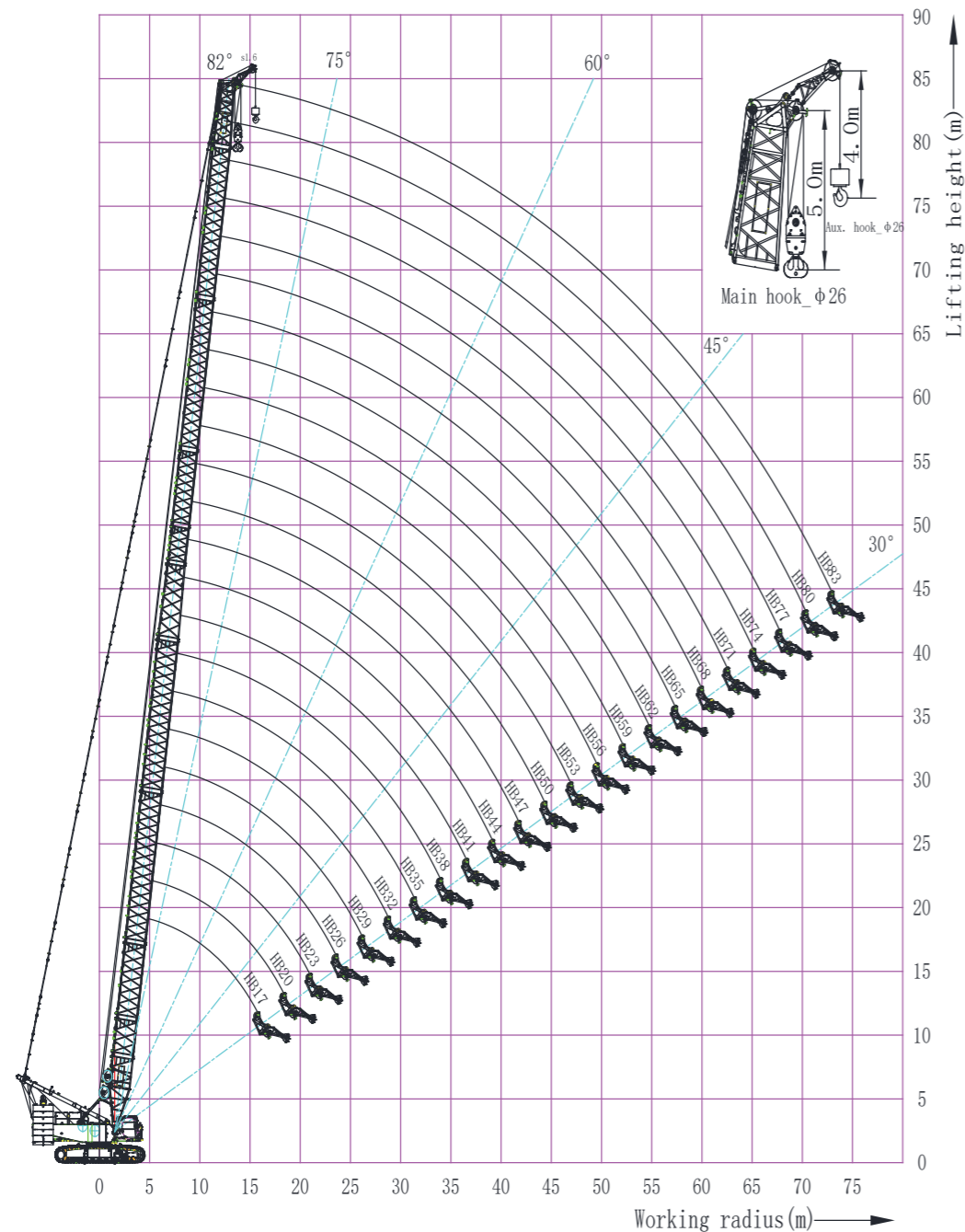

Working radius of main boom main hook under main boom working condition with boom single pulley (HBS/1)

Performance of main boom main hook under main boom working condition with boom single pulley auxiliary hook (HBS/1_75t+12t)

Working radius (m)	Main boom length (m)													
	17	20	23	26	29	32	35	38	41	44	47	50		
4.5	250.0													
5	220.0													
6	196.0	192.0	190.5	179.0										
7	177.0	176.0	174.5	173.5	167.0	156.0	144.0							
8	154.5	154.0	153.5	151.9	147.3	144.7	138.2	127.0	115.0	103.0				
9	136.0	136.0	135.2	133.4	131.0	127.0	124.0	121.0	109.0	103.0	101.0			
10	115.0	115.0	116.0	116.0	115.0	112.0	110.0	107.0	105.0	102.0	99.0	91.0		
12	87.5	87.9	88.2	88.3	88.4	88.4	88.4	87.2	85.5	83.8	82.2	80.6		
14	69.7	70.2	70.5	70.6	70.7	70.7	70.6	70.6	70.5	70.3	69.1	67.8		
16	57.4	58.0	58.3	58.4	58.5	58.5	58.4	58.3	58.3	58.1	58.0	57.9		
18		49.0	49.3	49.5	49.6	49.5	49.5	49.4	49.3	49.2	49.1	48.9		
20			42.5	42.6	42.7	42.7	42.7	42.6	42.5	42.4	42.2	42.1		
22				37.2	37.4	37.3	37.3	37.2	37.1	37.0	36.9	36.7		
24				32.8	33.0	33.0	33.0	32.9	32.8	32.6	32.5	32.3		
26					29.3	29.4	29.4	29.3	29.2	29.1	28.9	28.7		
28						26.3	26.3	26.2	26.2	26.0	25.9	25.7		
30							23.7	23.7	23.6	23.5	23.3	23.1		
32								21.5	21.4	21.4	21.2	20.9		
34									19.5	19.4	19.3	19.2	19.0	
36										17.7	17.6	17.4	17.3	
38											16.0	15.9	15.8	
40												14.7	14.6	14.4
42													13.3	13.2
44														12.1
Parts of line	18	18	16	14	13	12	11	10	9	9	8	8		

Notes:

1. Boom length exceeds 71m with “*”, center hitch must be used; boom length exceeds 74m, a wedge block must be used for boom raising.
2. 1 Tower jib rear pendant need to be removed from boom sections, tower jib guide pulley needs to be removed from boom top.

TYPICAL WORKING CONDITIONS

Performance of main boom main hook under main book working condition with boom single pulley auxiliary hook (HBS/1_75t+21t) (Continuous)

Working radius (m)	Main boom length (m)										
	53	56	59	62	65	68	71*	74*	77*	80*	83*
10	85.4	81.5	78.5	68.5							
12	79.4	77.9	76.4	66.5	65.5	62.6	60.2	55.0			
14	67.0	65.8	64.6	63.5	62.3	60.5	58.5	53.5	48.8	44.6	40.8
16	57.6	56.6	55.7	54.7	53.8	53.0	52.0	51.3	47.4	43.3	39.7
18	49.1	48.9	48.7	47.8	47.0	46.4	45.5	44.9	44.1	42.1	38.5
20	42.2	42.1	41.9	41.7	41.5	41.0	40.2	39.8	39.0	38.5	37.4
22	36.8	36.7	36.5	36.3	36.1	36.0	35.8	35.4	34.8	34.3	33.7
24	32.5	32.3	32.1	31.9	31.7	31.7	31.4	31.4	31.2	30.8	30.2
26	28.9	28.7	28.5	28.3	28.1	28.0	27.8	27.8	27.5	27.4	27.2
28	25.9	25.7	25.5	25.3	25.1	25.0	24.7	24.7	24.5	24.4	24.1
30	23.3	23.1	22.9	22.7	22.5	22.4	22.2	22.1	21.9	21.8	21.5
32	21.1	20.9	20.7	20.5	20.3	20.2	19.9	19.9	19.7	19.6	19.3
34	19.1	19.0	18.8	18.6	18.4	18.3	18.0	18.0	17.7	17.6	17.4
36	17.4	17.3	17.1	16.9	16.7	16.6	16.3	16.3	16.0	15.9	15.7
38	15.9	15.8	15.6	15.4	15.1	15.0	14.8	14.8	14.5	14.4	14.2
40	14.6	14.4	14.2	14.0	13.8	13.7	13.4	13.4	13.2	13.0	12.8
42	13.4	13.2	13.0	12.8	12.6	12.5	12.2	12.2	12.0	11.8	11.6
44	12.3	12.1	11.9	11.7	11.5	11.4	11.1	11.1	10.9	10.7	10.5
46	11.2	11.1	10.9	10.7	10.5	10.4	10.1	10.1	9.9	9.8	9.5
48		10.2	10.0	9.8	9.6	9.5	9.2	9.2	9.0	8.8	8.6
50		9.3	9.2	9.0	8.8	8.7	8.4	8.4	8.1	8.0	7.8
52			8.4	8.2	8.0	7.9	7.6	7.6	7.4	7.3	7.0
54				7.5	7.3	7.2	6.9	6.9	6.7	6.6	6.3
56					6.6	6.5	6.3	6.3	6.0	5.9	5.7
58					6.0	5.9	5.7	5.7	5.4	5.3	5.1
60						5.3	5.1	5.1	4.9	4.7	4.5
62							4.6	4.6	4.3	4.2	4.0
64								4.1	3.8	3.7	3.5
66								3.6	3.4	3.3	3.0
68									2.9	2.8	2.6
70										2.4	2.2
Parts of line	7	6	6	6	5	5	5	4	4	4	4

Notes:
 1. Boom length exceeds 71m with “**”, center hitch must be used; boom length exceeds 74m, a wedge block must be used for boom raising.
 2. 1 Tower jib rear pendant need to be removed from boom sections; tower jib guide pulley needs to be removed from boom top.

Performance of main boom main hook under main boom working condition with boom single pulley (HBS/1_65t+21t)

Working radius (m)	Main boom length (m)											
	17	20	23	26	29	32	35	38	41	44	47	50
4.5	250											
5	220											
6	196	192	190.5	179								
7	177	176	174.5	170	164	156	144					
8	151	151	147	142	138	134	131	127	115	103		
9	125	125	125	123	119	116	113	111	108	103	101	
10	105	106	106	106	105	102	100	98.3	96.1	94	91.9	89.9
12	79.8	80.2	80.5	80.6	80.7	80.7	80.7	79.5	77.9	76.4	74.9	73.4
14	63.5	63.9	64.2	64.3	64.4	64.4	64.4	64.3	64.2	63.9	62.8	61.6
16	52.2	52.7	53	53.1	53.2	53.2	53.1	53.1	53	52.9	52.7	52.6
18		44.4	44.8	44.9	45	45	44.9	44.8	44.7	44.6	44.5	44.4
20			38.5	38.6	38.7	38.7	38.7	38.6	38.5	38.4	38.2	38.1
22				33.6	33.8	33.8	33.7	33.6	33.5	33.4	33.3	33.1
24				29.6	29.7	29.7	29.7	29.6	29.5	29.4	29.3	29.1
26					26.4	26.4	26.4	26.3	26.2	26.1	25.9	25.8
28						23.6	23.6	23.5	23.4	23.3	23.2	23
30							21.2	21.1	21.1	20.9	20.8	20.6
32							19.1	19.1	19	18.9	18.7	18.6
34								17.3	17.2	17.1	17	16.8
36									15.6	15.5	15.4	15.2
38										14.1	14	13.8
40										12.8	12.7	12.6
42											11.6	11.4
44												10.4
Parts of line	18	18	16	14	13	12	11	10	9	9	8	8

Notes:
 1. Boom length exceeds 71m with “**”, center hitch must be used; boom length exceeds 74m, a wedge block must be used for boom raising.
 2. 1 Tower jib rear pendant need to be removed from boom sections; tower jib guide pulley needs to be removed from boom top.

TYPICAL WORKING CONDITIONS

Performance of main boom main hook under main boom working condition with boom single pulley auxiliary hook (HBS/1_65t+21t) (continuous table)

Working radius (m)	Main boom length (m)									
	53	56	59	62	65	68	71*	74*	77*	80*
10	85.4	81.5	78.5	68.5						
12	72.3	70.9	69.5	66.5	65.5	62.6	60.2	55		
14	60.9	59.8	58.7	57.6	56.5	55.6	54.5	53.5	48.8	44.6
16	52.2	51.3	50.4	49.5	48.7	47.9	47	46.3	45.5	43.3
18	44.5	44.4	44	43.2	42.4	41.8	41	40.5	39.7	39.1
20	38.2	38.1	37.9	37.7	37.4	36.9	36.2	35.7	35	34.5
22	33.2	33.1	32.9	32.7	32.5	32.4	32.1	31.7	31.1	30.7
24	29.2	29.1	28.9	28.7	28.5	28.4	28.1	28.1	27.8	27.4
26	25.9	25.8	25.6	25.4	25.2	25.1	24.8	24.8	24.6	24.4
28	23.1	23	22.8	22.6	22.4	22.3	22	22	21.8	21.6
30	20.8	20.6	20.4	20.2	20	19.9	19.6	19.6	19.4	19.3
32	18.7	18.6	18.4	18.2	17.9	17.9	17.6	17.6	17.3	17.2
34	16.9	16.8	16.6	16.4	16.2	16.1	15.8	15.8	15.5	15.4
36	15.4	15.2	15	14.8	14.6	14.5	14.2	14.2	14	13.8
38	14	13.8	13.6	13.4	13.2	13.1	12.8	12.8	12.6	12.5
40	12.7	12.6	12.4	12.2	12	11.9	11.6	11.6	11.3	11.2
42	11.6	11.4	11.3	11.1	10.8	10.7	10.5	10.5	10.2	10.1
44	10.6	10.4	10.2	10.1	9.8	9.7	9.5	9.5	9.2	9.1
46	9.7	9.5	9.3	9.1	8.9	8.8	8.6	8.5	8.3	8.2
48		8.7	8.5	8.3	8.1	8	7.7	7.7	7.5	7.3
50		7.9	7.7	7.5	7.3	7.2	7	6.9	6.7	6.6
52			7	6.8	6.6	6.5	6.2	6.2	6	5.9
54				6.2	5.9	5.9	5.6	5.6	5.3	5.2
56					5.3	5.3	5	5	4.7	4.6
58					4.8	4.7	4.4	4.4	4.2	4.1
60						4.2	3.9	3.9	3.7	3.5
62							3.4	3.4	3.2	3.1
64								3	2.7	2.6
66								2.5	2.3	2.2
Parts of line	7	6	6	6	5	5	5	4	4	4

Notes:
 1. Boom length exceeds 71m with “*”, center hitch must be used; boom length exceeds 74m, a wedge block must be used for boom raising.
 2. Tower jib rear pendant need to be removed from boom sections, tower jib guide pulley needs to be removed from boom top.

Performance of main boom main hook under main boom working condition with boom single pulley auxiliary hook (HBS/1_55t+21t) (continuous table)

Working radius (m)	Main boom length (m)											
	17	20	23	26	29	32	35	38	41	44	47	50
5	200											
6	196	192	190.5	179								
7	169	165	159	154	149	144	139					
8	138	137	133	129	125	122	118	115	112	103		
9	113	113	114	111	108	105	103	100	98.2	95.8	93.5	
10	95.6	96	96.3	96.5	95.4	93.2	91	89	86.9	85	83.1	81.2
12	72.1	72.5	72.8	72.9	73	73	73	71.8	70.3	68.9	67.5	66.2
14	57.2	57.7	58	58.1	58.1	58.1	58.1	58	58	57.6	56.5	55.5
16	46.9	47.4	47.7	47.8	47.9	47.9	47.9	47.8	47.7	47.6	47.5	47.3
18		39.8	40.2	40.3	40.4	40.4	40.4	40.3	40.2	40.1	39.9	39.8
20			34.4	34.6	34.7	34.7	34.6	34.5	34.5	34.3	34.2	34
22				30	30.2	30.2	30.1	30	29.9	29.8	29.7	29.5
24				26.3	26.5	26.5	26.5	26.4	26.3	26.1	26	25.8
26					23.4	23.4	23.4	23.3	23.3	23.1	23	22.8
28						20.9	20.9	20.8	20.7	20.6	20.4	20.3
30							18.7	18.6	18.5	18.4	18.3	18.1
32							16.8	16.7	16.7	16.5	16.4	16.2
34								15.1	15	14.9	14.8	14.6
36									13.6	13.5	13.3	13.2
38										12.2	12	11.9
40										11	10.9	10.7
42											9.9	9.7
44												8.8
Parts of line	18	18	16	14	13	12	11	10	9	9	8	8

Notes:
 1. Boom length exceeds 71m with “*”, center hitch must be used; boom length exceeds 74m, a wedge block must be used for boom raising.
 2. Tower jib rear pendant need to be removed from boom sections, tower jib guide pulley needs to be removed from boom top.

TYPICAL WORKING CONDITIONS

Performance of main boom main hook under main boom working condition with boom single pulley auxiliary hook (HBS/1_55t+21t) (continuous table)

Working radius (m)	Main boom length (m)							
	53	56	59	62	65	68	71*	74*
10	79.7	78	76.3	68.5				
12	65.2	63.9	62.7	61.4	60.2	59.1	57.8	
14	54.7	53.7	52.7	51.7	50.7	49.9	48.9	47.2
16	46.9	46	45.2	44.4	43.5	42.9	42	40.6
18	39.9	39.8	39.3	38.6	37.9	37.3	36.5	35.3
20	34.2	34	33.9	33.7	33.3	32.8	32.1	31.0
22	29.7	29.5	29.3	29.1	28.9	28.8	28.4	27.5
24	26	25.8	25.6	25.4	25.2	25.2	24.9	24.5
26	23	22.8	22.6	22.4	22.2	22.1	21.9	21.6
28	20.4	20.2	20.1	19.9	19.6	19.6	19.3	19.0
30	18.2	18.1	17.9	17.7	17.5	17.4	17.1	16.9
32	16.4	16.2	16	15.8	15.6	15.5	15.2	15.0
34	14.7	14.6	14.4	14.2	14	13.9	13.6	13.3
36	13.3	13.1	13	12.8	12.5	12.4	12.2	11.9
38	12	11.9	11.7	11.5	11.3	11.2	10.9	10.6
40	10.9	10.7	10.5	10.3	10.1	10	9.8	9.5
42	9.9	9.7	9.5	9.3	9.1	9	8.7	8.5
44	8.9	8.8	8.6	8.4	8.2	8.1	7.8	7.6
46	8.1	7.9	7.8	7.6	7.3	7.2	7	6.7
48		7.2	7	6.8	6.6	6.5	6.2	6.0
50		6.4	6.3	6.1	5.9	5.8	5.5	5.3
52			5.6	5.4	5.2	5.1	4.9	4.6
54				4.8	4.6	4.5	4.3	4.0
56					4.1	4	3.7	3.5
58					3.5	3.5	3.2	3.0
60						3	2.7	2.5
62							2.3	2.0
Parts of line	7	6	6	6	5	5	5	4

Notes:
 1. Boom length exceeds 71m with “*” , center hitch must be used; boom length exceeds 74m, a wedge block must be used for boom raising.
 2. 1 Tower jib rear pendant need to be removed from boom sections; tower jib guide pulley needs to be removed from boom top.

1.3 Characteristics of boom single pulley auxiliary hook under main boom working condition with main boom main hook (HBS/2)

Working radius of boom single pulley auxiliary hook under main boom working condition with main boom main hook (HBS/2)

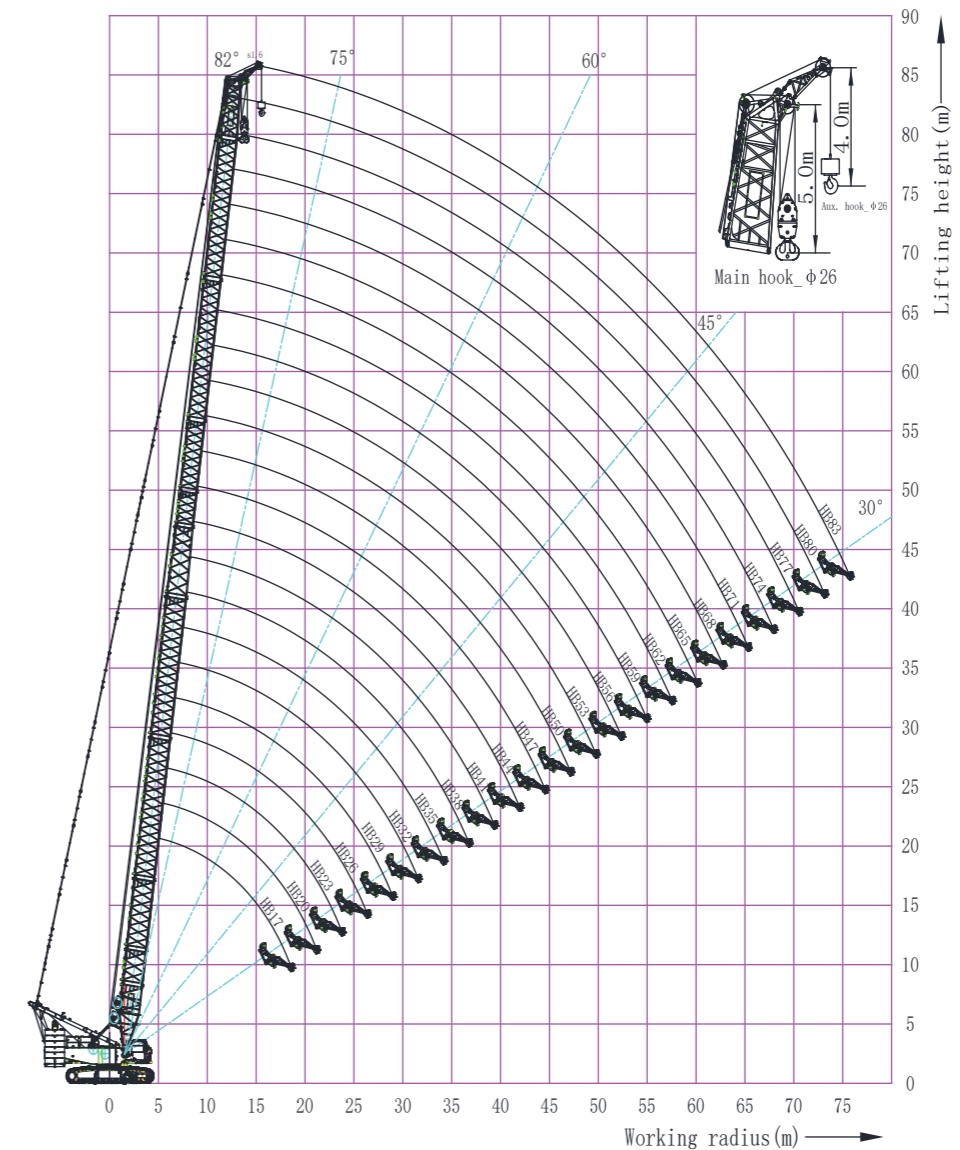

Working radius of boom single pulley auxiliary hook under main boom working condition without main boom main hook (HBS/2)

TYPICAL WORKING CONDITIONS

Performance of boom single pulley auxiliary hook under main boom working condition with main boom main hook (HBS/2_75t+21t)

Working radius (m)	Main boom length (m)											
	17	20	23	26	29	32	35	38	41	44	47	50
6	13.5											
7	13.5	13.5	13.5	13.5								
8	13.5	13.5	13.5	13.5	13.5	13.5	13.5					
9	13.5	13.5	13.5	13.5	13.5	13.5	13.5	13.5	13.5	13.5		
10	13.5	13.5	13.5	13.5	13.5	13.5	13.5	13.5	13.5	13.5	13.5	
12	13.5	13.5	13.5	13.5	13.5	13.5	13.5	13.5	13.5	13.5	13.5	13.5
14	13.5	13.5	13.5	13.5	13.5	13.5	13.5	13.5	13.5	13.5	13.5	13.5
16	13.5	13.5	13.5	13.5	13.5	13.5	13.5	13.5	13.5	13.5	13.5	13.5
18		13.5	13.5	13.5	13.5	13.5	13.5	13.5	13.5	13.5	13.5	13.5
20			13.5	13.5	13.5	13.5	13.5	13.5	13.5	13.5	13.5	13.5
22				13.5	13.5	13.5	13.5	13.5	13.5	13.5	13.5	13.5
24				13.5	13.5	13.5	13.5	13.5	13.5	13.5	13.5	13.5
26					13.5	13.5	13.5	13.5	13.5	13.5	13.5	13.5
28						13.5	13.5	13.5	13.5	13.5	13.5	13.5
30							13.5	13.5	13.5	13.5	13.5	13.5
32								13.5	13.5	13.5	13.5	13.5
34									13.5	13.5	13.5	13.5
36										13.5	13.5	13.5
38											13.5	13.5
40												13.5
42												12.5
44												11.2
Parts of line	1	1	1	1	1	1	1	1	1	1	1	1

- Notes:
 1. Boom length exceeds 71m with “**”, center hitch must be used; boom length exceeds 74m, a wedge block must be used for boom raising.
 2. Tower jib rear pendant need to be removed from boom sections; tower jib guide pulley needs to be removed from boom top.

Performance of boom single pulley auxiliary hook under main boom working condition with main boom main hook (HBS/2_75t+21t)

Working radius (m)	Main boom length (m)										
	53	56	59	62	65	68	71*	74*	77*	80*	83*
12	13.5	13.5	13.5	13.5							
14	13.5	13.5	13.5	13.5	13.5	13.5	13.5	13.5			
16	13.5	13.5	13.5	13.5	13.5	13.5	13.5	13.5	13.5	13.5	13.5
18	13.5	13.5	13.5	13.5	13.5	13.5	13.5	13.5	13.5	13.5	13.5
20	13.5	13.5	13.5	13.5	13.5	13.5	13.5	13.5	13.5	13.5	13.5
22	13.5	13.5	13.5	13.5	13.5	13.5	13.5	13.5	13.5	13.5	13.5
24	13.5	13.5	13.5	13.5	13.5	13.5	13.5	13.5	13.5	13.5	13.5
26	13.5	13.5	13.5	13.5	13.5	13.5	13.5	13.5	13.5	13.5	13.5
28	13.5	13.5	13.5	13.5	13.5	13.5	13.5	13.5	13.5	13.5	13.5
30	13.5	13.5	13.5	13.5	13.5	13.5	13.5	13.5	13.5	13.5	13.5
32	13.5	13.5	13.5	13.5	13.5	13.5	13.5	13.5	13.5	13.5	13.5
34	13.5	13.5	13.5	13.5	13.5	13.5	13.5	13.5	13.5	13.5	13.5
36	13.5	13.5	13.5	13.5	13.5	13.5	13.5	13.5	13.5	13.5	13.5
38	13.5	13.5	13.5	13.5	13.5	13.5	13.5	13.5	13.5	13.5	13.4
40	13.5	13.5	13.4	13.2	13.0	12.9	12.6	12.6	12.4	12.2	12.0
42	12.5	12.3	12.1	12.0	11.7	11.6	11.4	11.4	11.1	11.0	10.8
44	11.4	11.2	11.0	10.8	10.6	10.5	10.3	10.2	10.0	9.9	9.7
46	10.3	10.2	10.0	9.8	9.6	9.5	9.3	9.2	9.0	8.9	8.6
48		9.2	9.1	8.9	8.7	8.6	8.3	8.3	8.1	8.0	7.7
50		8.4	8.2	8.0	7.8	7.7	7.5	7.5	7.2	7.1	6.9
52			7.4	7.3	7.0	7.0	6.7	6.7	6.5	6.3	6.1
54				6.5	6.3	6.2	6.0	6.0	5.7	5.6	5.4
56					5.6	5.6	5.3	5.3	5.1	4.9	4.7
58						5.0	4.9	4.7	4.7	4.4	4.1
60							4.3	4.1	4.1	3.9	3.5
62								3.6	3.6	3.3	3.0
64									3.0	2.8	2.5
66										2.6	2.2
68											1.9
Parts of line	1	1	1	1	1	1	1	1	1	1	1

- Notes:
 1. Boom length exceeds 71m with “**”, center hitch must be used; boom length exceeds 74m, a wedge block must be used for boom raising.
 2. Tower jib rear pendant need to be removed from boom sections; tower jib guide pulley needs to be removed from boom top.

TYPICAL WORKING CONDITIONS

Performance of boom single pulley auxiliary hook under main boom working condition with main boom main hook (HBS/2_65t+21t)

Working radius (m)	Main boom length (m)												
	17	20	23	26	29	32	35	38	41	44	47	50	
6	13.5												
7	13.5	13.5	13.5	13.5									
8	13.5	13.5	13.5	13.5	13.5	13.5	13.5						
9	13.5	13.5	13.5	13.5	13.5	13.5	13.5	13.5	13.5	13.5			
10	13.5	13.5	13.5	13.5	13.5	13.5	13.5	13.5	13.5	13.5	13.5		
12	13.5	13.5	13.5	13.5	13.5	13.5	13.5	13.5	13.5	13.5	13.5	13.5	
14	13.5	13.5	13.5	13.5	13.5	13.5	13.5	13.5	13.5	13.5	13.5	13.5	
16	13.5	13.5	13.5	13.5	13.5	13.5	13.5	13.5	13.5	13.5	13.5	13.5	
18		13.5	13.5	13.5	13.5	13.5	13.5	13.5	13.5	13.5	13.5	13.5	
20			13.5	13.5	13.5	13.5	13.5	13.5	13.5	13.5	13.5	13.5	
22				13.5	13.5	13.5	13.5	13.5	13.5	13.5	13.5	13.5	
24				13.5	13.5	13.5	13.5	13.5	13.5	13.5	13.5	13.5	
26					13.5	13.5	13.5	13.5	13.5	13.5	13.5	13.5	
28						13.5	13.5	13.5	13.5	13.5	13.5	13.5	
30							13.5	13.5	13.5	13.5	13.5	13.5	
32							13.5	13.5	13.5	13.5	13.5	13.5	
34								13.5	13.5	13.5	13.5	13.5	
36									13.5	13.5	13.5	13.5	
38										13.3	13.2	13	
40											12	11.9	
42												10.7	
44													9.5
Parts of line	1	1	1	1	1	1	1	1	1	1	1	1	1

Notes:
 1. Boom length exceeds 71m with “*”, center hitch must be used; boom length exceeds 74m, a wedge block must be used for boom raising.
 2. 1 Tower jib rear pendant need to be removed from boom sections; tower jib guide pulley needs to be removed from boom top.

Performance of boom single pulley auxiliary hook under main boom working condition with main boom main hook (HBS/2_65t+21t)

Working radius (m)	Main boom length (m)									
	53	56	59	62	65	68	71*	74*	77*	80*
12	13.5	13.5	13.5	13.5						
14	13.5	13.5	13.5	13.5	13.5	13.5	13.5	13.5		
16	13.5	13.5	13.5	13.5	13.5	13.5	13.5	13.5	13.5	13.5
18	13.5	13.5	13.5	13.5	13.5	13.5	13.5	13.5	13.5	13.5
20	13.5	13.5	13.5	13.5	13.5	13.5	13.5	13.5	13.5	13.5
22	13.5	13.5	13.5	13.5	13.5	13.5	13.5	13.5	13.5	13.5
24	13.5	13.5	13.5	13.5	13.5	13.5	13.5	13.5	13.5	13.5
26	13.5	13.5	13.5	13.5	13.5	13.5	13.5	13.5	13.5	13.5
28	13.5	13.5	13.5	13.5	13.5	13.5	13.5	13.5	13.5	13.5
30	13.5	13.5	13.5	13.5	13.5	13.5	13.5	13.5	13.5	13.5
32	13.5	13.5	13.5	13.5	13.5	13.5	13.5	13.5	13.5	13.5
34	13.5	13.5	13.5	13.5	13.5	13.5	13.5	13.5	13.5	13.5
36	13.5	13.5	13.5	13.5	13.5	13.5	13.5	13.4	13.2	13.1
38	13.2	13	12.8	12.6	12.4	12.3	12	12	11.8	11.7
40	11.9	11.7	11.5	11.4	11.1	11	10.8	10.8	10.5	10.4
42	10.7	10.6	10.4	10.2	10	9.9	9.6	9.6	9.4	9.3
44	9.7	9.5	9.4	9.2	9	8.9	8.6	8.6	8.4	8.2
46	8.8	8.6	8.4	8.2	8	7.9	7.7	7.7	7.4	7.3
48		7.7	7.6	7.4	7.2	7.1	6.8	6.8	6.6	6.4
50		6.9	6.8	6.6	6.4	6.3	6	6	5.8	5.7
52			6	5.9	5.7	5.6	5.3	5.3	5.1	4.9
54				5.2	5	4.9	4.6	4.6	4.4	4.3
56					4.4	4.3	4	4	3.8	3.7
58						3.8	3.7	3.4	3.4	3.2
60							3.2	2.9	2.9	2.7
62								2.4	2.4	2.2
64									1.9	1.7
66									1.5	
Parts of line	1	1	1	1	1	1	1	1	1	1

Notes:
 1. Boom length exceeds 71m with “*”, center hitch must be used; boom length exceeds 74m, a wedge block must be used for boom raising.
 2. Tower jib rear pendant need to be removed from boom sections; tower jib guide pulley needs to be removed from boom top.

TYPICAL WORKING CONDITIONS

Performance of boom single pulley auxiliary hook under main boom working condition with main boom main hook (HBS/2_55t+21t)

Working radius (m)	Main boom length (m)											
	17	20	23	26	29	32	35	38	41	44	47	50
6	13.5											
7	13.5	13.5	13.5	13.5								
8	13.5	13.5	13.5	13.5	13.5	13.5	13.5					
9	13.5	13.5	13.5	13.5	13.5	13.5	13.5	13.5	13.5	13.5		
10	13.5	13.5	13.5	13.5	13.5	13.5	13.5	13.5	13.5	13.5	13.5	
12	13.5	13.5	13.5	13.5	13.5	13.5	13.5	13.5	13.5	13.5	13.5	13.5
14	13.5	13.5	13.5	13.5	13.5	13.5	13.5	13.5	13.5	13.5	13.5	13.5
16	13.5	13.5	13.5	13.5	13.5	13.5	13.5	13.5	13.5	13.5	13.5	13.5
18		13.5	13.5	13.5	13.5	13.5	13.5	13.5	13.5	13.5	13.5	13.5
20			13.5	13.5	13.5	13.5	13.5	13.5	13.5	13.5	13.5	13.5
22				13.5	13.5	13.5	13.5	13.5	13.5	13.5	13.5	13.5
24				13.5	13.5	13.5	13.5	13.5	13.5	13.5	13.5	13.5
26					13.5	13.5	13.5	13.5	13.5	13.5	13.5	13.5
28						13.5	13.5	13.5	13.5	13.5	13.5	13.5
30							13.5	13.5	13.5	13.5	13.5	13.5
32							13.5	13.5	13.5	13.5	13.5	13.5
34								13.5	13.5	13.5	13.5	13.5
36									12.8	12.7	12.5	12.4
38										11.4	11.2	11.1
40										10.2	10.1	9.9
42											9	8.9
44												7.9
Parts of line	1	1	1	1	1	1	1	1	1	1	1	1

Notes:
 1. Boom length exceeds 71m with “**”, center hitch must be used; boom length exceeds 74m, a wedge block must be used for boom raising.
 2. 1 Tower jib rear pendant need to be removed from boom sections; tower jib guide pulley needs to be removed from boom top.

Performance of boom single pulley auxiliary hook under main boom working condition with main boom main hook (HBS/2_55t+21t) (continuous table)

Working radius (m)	Main boom length (m)							
	53	56	59	62	65	68	71*	74*
12	13.5	13.5	13.5	13.5				
14	13.5	13.5	13.5	13.5	13.5	13.5	13.5	13.5
16	13.5	13.5	13.5	13.5	13.5	13.5	13.5	13.5
18	13.5	13.5	13.5	13.5	13.5	13.5	13.5	13.5
20	13.5	13.5	13.5	13.5	13.5	13.5	13.5	13.5
22	13.5	13.5	13.5	13.5	13.5	13.5	13.5	13.5
24	13.5	13.5	13.5	13.5	13.5	13.5	13.5	13.5
26	13.5	13.5	13.5	13.5	13.5	13.5	13.5	13.5
28	13.5	13.5	13.5	13.5	13.5	13.5	13.5	13.5
30	13.5	13.5	13.5	13.5	13.5	13.5	13.5	13.5
32	13.5	13.5	13.5	13.5	13.5	13.5	13.5	13.5
34	13.5	13.5	13.5	13.4	13.2	13.1	12.9	12.9
36	12.5	12.4	12.2	12	11.8	11.7	11.4	11.4
38	11.2	11.1	10.9	10.7	10.5	10.4	10.1	10.1
40	10.1	9.9	9.7	9.5	9.3	9.2	8.9	8.9
42	9	8.8	8.7	8.5	8.3	8.2	7.9	7.9
44	8	7.9	7.7	7.5	7.3	7.2	7	6.9
46	7.2	7	6.8	6.7	6.4	6.4	6.1	6.1
48		6.2	6.1	5.9	5.7	5.6	5.3	5.3
50		5.5	5.3	5.2	4.9	4.9	4.6	4.6
52			4.7	4.5	4.3	4.2	3.9	3.9
54				3.9	3.7	3.6	3.3	3.3
56					3.1	3	2.7	2.7
58						2.5	2.2	2.2
60							2	1.7
Parts of line	1	1	1	1	1	1	1	1

Notes:
 1. Boom length exceeds 71m with “**”, center hitch must be used; boom length exceeds 74m, a wedge block must be used for boom raising.
 2. 1 Tower jib rear pendant need to be removed from boom sections; tower jib guide pulley needs to be removed from boom top.

TYPICAL WORKING CONDITIONS

2. Tower jib working condition

2.1 Combinations of main boom sections under tower jib working condition

Main boom combination	Name and qty.	Boom Butt 6m	Insert section 3mA	Insert section 6mA	Insert section 12mA	Boom transition section 6m	Insert section 3mB	Insert section 6mB	Insert section 12mB	Boom top 5m
HB20		1	1	0	0	1	0	0	0	1
HB23		1	0	1	0	1	0	0	0	1
HB26		1	1	1	0	1	0	0	0	1
HB29		1	0	0	1	1	0	0	0	1
HB32		1	1	0	1	1	0	0	0	1
HB35		1	0	1	1	1	0	0	0	1
HB38		1	1	1	1	1	0	0	0	1
HB41		1	0	0	2	1	0	0	0	1
HB44		1	1	0	2	1	0	0	0	1
HB47		1	0	1	2	1	0	0	0	1
HB50		1	1	1	2	1	0	0	0	1
HB53		1	0	0	2	1	0	0	1	1
HB56		1	1	0	2	1	0	0	1	1

2.2 Combinations of jib sections under tower jib working condition

Main boom combination	Name and qty.	Tower jib butt 1.5m	Insert section 3mB	Insert section 6mB	Insert section 12mB	Tower jib transition section 4.5m	Insert section 3mC	Insert section 6mC	Insert section 12mC	Tower jib top section 3m
W18		1	1	1	0	1	0	0	0	1
W21		1	1	1	0	1	1	0	0	1
W24		1	1	1	0	1	0	1	0	1
W27		1	1	0	1	1	1	0	0	1
W30		1	1	1	1	1	0	0	0	1
W33		1	1	1	1	1	1	0	0	1
W36		1	1	1	1	1	0	1	0	1
W39		1	1	1	1	1	1	1	0	1
W42		1	1	1	1	1	0	0	1	1
W45		1	1	1	1	1	1	0	1	1
W48		1	1	1	1	1	0	1	1	1
*W51		1	1	1	1	1	1	1	1	1
*W54		1	1	1	1	1	0	0	2	1
*W57		1	1	1	1	1	1	0	2	1
*W60		1	1	1	1	1	0	1	2	1
*W63		1	1	1	1	1	1	1	2	1

Notes:

1. "*" means tower jib length that need to use center hitch.
2. Tower jib rear pendants must be installed for boom sections; tower jib guide pulley must be installed for boom top section.
3. When the combination length of the main boom and tower jib exceeds 71m, a wedge block is recommended to be used to raise the boom (jib).

TYPICAL WORKING CONDITIONS

2.3 Boom raising table of tower jib working condition (HW) (counterweight combination 75t+21t)

Main boom Tower jib	HB20	HB23	HB26	HB29	HB32	HB35	HB38	HB41	HB44	HB47	HB50	HB53	HB56
W18	●	●	●	●	●	●	●	●	●	●	●	●	●
W21	●	●	●	●	●	●	●	●	●	●	●	●	●
W24	●	●	●	●	●	●	●	●	●	●	●	●	●
W27	●	●	●	●	●	●	●	●	●	●	●	●	●
W30	●	●	●	●	●	●	●	●	●	●	●	●	●
W33	●	●	●	●	●	●	●	●	●	●	●	●	●
W36	●	●	●	●	●	●	●	●	●	●	●	●	●
W39	●	●	●	●	●	●	●	●	●	●	●	●	●
W42	●	●	●	●	●	●	●	●	●	●	●	●	●
W45	●	●	●	●	●	●	●	●	●	●	●	●	×
W48	●	●	●	●	●	●	●	●	●	●	●	●	×
*W51	●	●	●	●	●	●	●	●	●	●	●	●	×
*W54	●	●	●	●	●	●	●	●	●	●	●	●	×
*W57	●	●	●	●	●	●	●	●	●	●	●	●	×
*W60	●	●	●	●	●	●	●	●	●	●	●	●	×
*W63	●	●	●	●	●	●	●	●	●	●	●	×	×

Notes:

- When raising boom, place the drive roller of crawler tracks at the rear of the crane body.
- “●” —means boom raising is allowable, “×” —means boom raising is not allowable, this working condition cannot be used.
- “*” means tower jib length that need to use center hitch.
- For the combinations which the length of boom plus the length of jib exceeds 71m, if it is available, a wedge block is recommended to be used to ensure the safety of boom (jib) raising and lowering.

2.4 Partial lifting performance of tower jib working condition (HW)

Notes:

- The actual lifting weight is the remained weight after the weights of hook, slings and wire ropes reeved on hook and boom (jib) head are subtracted from the rated lifting load in table.
- The rated loads in the table are the lifted values when the loads are lifted slowly and stably in non-travelling state on plane and solid ground with the gradient no more than 1%.
- The load values given in the table are the load hanging freely without consideration of the influence of wind load to the lifted load, the ground condition, gradient, operation speed and nay other factors negatively impact on the safe operation of the crane. Thus, the operator is responsible for the current situation judgment, reducing the lifted load correspondingly and reducing the speed.
- When tower jib length exceeds 48m, a center hitch must be used; When the combination length of the main boom and jib exceeds 71m, a wedge block is recommended to be used to raise the boom (jib).

2.4 Working radius of tower jib working condition (HW)

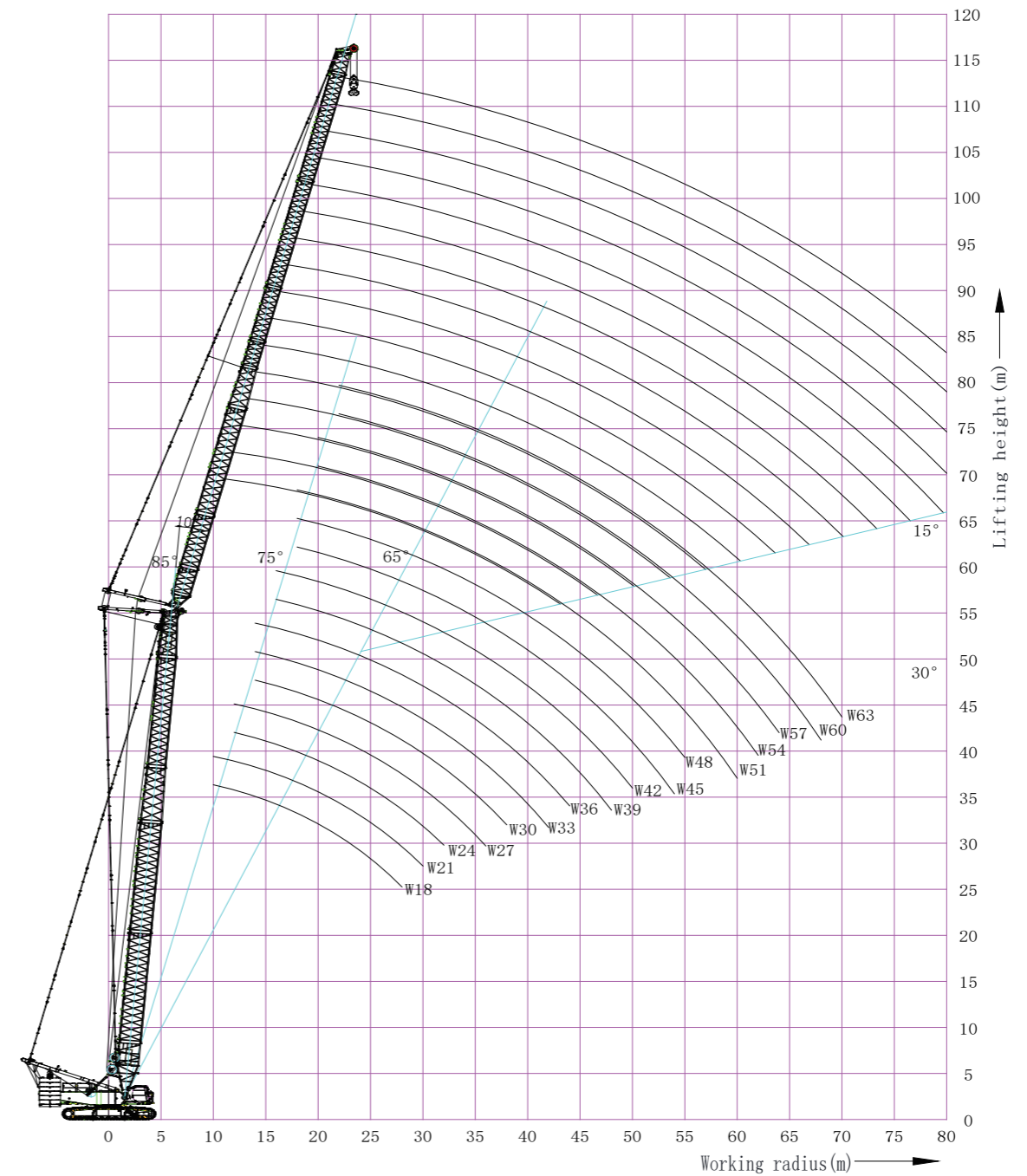

Working radius of tower jib working condition (HW)

TYPICAL WORKING CONDITIONS

A. Main boom working angle is 85°

Main boom 20m, Boom angle 85°																
Radius/m	Tower jib length/m															
	18	21	24	27	30	33	36	39	42	45	48	51	54	57	60	63
10	80	77.8														
12	72.7	75.5	70.6	75.5												
14	62.7	64.1	61.7	63.8	65.6	59.8	53.4									
16	49.6	51.4	52.5	52.9	53.2	50.4	45.4	42.9	39.1							
18	39.9	42.1	43.4	44	44.3	43.4	39.3	37.3	34.2	32.2	29.2	32.9				
20	31.7	34.9	36.5	37.2	37.6	37.9	34.5	32.8	30.1	28.4	25.8	29.4	31	28.9		
22		28.8	30.9	31.8	32.4	32.8	30.5	29.1	26.8	25.3	23	26.4	27.8	27.9	24.3	22.2
24		22.8	26.2	27.4	28.1	28.6	27.3	26	23.9	22.5	20.5	23.7	25	25.2	23.4	21.3
26			21.7	23.6	24.5	25.1	24.5	23.3	21.5	20.2	18.4	21.3	22.5	22.6	22.5	20.5
28				20.1	21.3	22.1	22.2	21.1	19.5	18.2	16.6	19.3	20.3	20.4	20.5	19.6
30				16.4	18.5	19.4	20.1	19.1	17.7	16.5	15	17.4	18.4	18.4	18.5	18.3
32					15.7	17.1	17.9	17.4	16.1	14.9	13.6	15.8	16.7	16.7	16.8	16.6
34						14.8	15.8	15.9	14.7	13.6	12.3	14.4	15.2	15.2	15.3	15
36							13.9	14.6	13.5	12.4	11.2	13.1	13.9	13.9	13.9	13.7
38							11.9	12.9	12.4	11.3	10.2	12	12.7	12.7	12.7	12.5
40								11.3	11.4	10.4	9.3	11	11.6	11.6	11.6	11.4
42									10.5	9.5	8.4	10	10.7	10.6	10.6	10.4
44									9.3	8.7	7.7	9.2	9.8	9.7	9.7	9.5
46										8	7	8.4	9	8.9	8.9	8.7
48												6.4	7.7	8.2	8.2	8.2
50												5.8	7	7.5	7.5	7.5
52													6.4	6.9	6.8	6.8
54														6.3	6.2	6.2
56														5.6	5.7	5.7
58															5.2	5.1
60																4.6
62																
64																
Counterweight	75+21	75+21	75+21	75+21	75+21	75+21	75+21	75+21	75+21	75+21	75+21	75+21	75+21	75+21	75+21	75+21
Parts of line	6	6	6	6	5	5	4	4	3	3	3	3	3	3	2	2

A. Main boom working angle is 85°

Main boom 26m, Boom angle 85°																
Radius/m	Tower jib length/m															
	18	21	24	27	30	33	36	39	42	45	48	51	54	57	60	63
10	80															
12	74.3	75.6	70.5													
14	66.1	66.6	63.6	63	60.9	59										
16	53	54.6	54.7	55.8	54.8	52	46.7	43.9	39.9							
18	42.6	44.6	45.8	46.3	46.6	44.6	40.3	38.2	34.9	32.8	29.8					
20	34.2	36.9	38.4	39	39.4	38.9	35.3	33.6	30.8	29	26.3	29.8	31	28.2		
22		30.6	32.5	33.4	33.8	34.2	31.2	29.8	27.3	25.8	23.4	26.8	28.2	27.3	23.8	21.8
24		24.8	27.6	28.7	29.3	29.8	27.9	26.6	24.4	23	20.9	24.1	25.4	25.5	23	21
26			23.2	24.8	25.6	26.1	25	23.8	22	20.6	18.8	21.7	22.8	23	22.2	20.3
28				21.2	22.3	23	22.7	21.5	19.9	18.6	16.9	19.6	20.6	20.7	20.8	19.6
30				17.7	19.4	20.3	20.6	19.5	18	16.8	15.3	17.8	18.7	18.7	18.8	18.6
32					16.7	17.9	18.6	17.8	16.4	15.2	13.8	16.1	17	17	17.1	16.8
34						15.6	16.5	16.2	15	13.9	12.5	14.7	15.5	15.5	15.5	15.3
36							13.2	14.6	14.9	13.7	12.6	11.4	13.4	14.1	14.1	13.9
38								12.6	13.6	12.6	11.5	10.4	12.2	12.9	12.9	12.7
40									11.9	11.6	10.6	9.4	11.2	11.8	11.8	11.6
42									10.2	10.7	9.7	8.6	10.2	10.8	10.8	10.6
44										9.8	8.9	7.8	9.3	9.9	9.9	9.6
46											8.1	7.1	8.5	9.1	9.1	8.8
48												6.5	7.8	8.4	8.3	8
50												5.9	7.1	7.7	7.6	7.3
52													6.5	7.1	7	6.6
54														6.5	6.4	6
56														5.9	5.8	5.5
58															5.3	4.9
60																4.8
62																4.3
64																4
Counterweight	75+21	75+21	75+21	75+21	75+21	75+21	75+21	75+21	75+21	75+21	75+21	75+21	75+21	75+21	75+21	75+21
Parts of line	6	6	6	5	5	5	4	4	3	3	3	3	3	3	2	2

TYPICAL WORKING CONDITIONS

A. Main boom working angle is 85°

Main boom 32m, Boom angle 85°																
Radius/m	Tower jib length/m															
	18	21	24	27	30	33	36	39	42	45	48	51	54	57	60	63
12	74.7	72.4	70													
14	64.9	63.4	61.7	59.7	57.7											
16	56.5	56	54.8	53.4	51.8	50.3	47.9	44.8								
18	45.3	47.1	48.2	48	46.7	45.5	41.4	39	35.6	33.4	30.3					
20	36.5	39	40.3	40.9	41.2	39.9	36.2	34.3	31.4	29.5	26.8	30.1	30.1			
22	28.5	32.4	34.1	34.9	35.3	35.2	32	30.4	27.9	26.3	23.9	27.1	28.5	26.6	23.3	21.4
24		26.6	29	30	30.5	31.1	28.5	27.2	24.9	23.5	21.3	24.4	25.7	25.8	22.5	20.6
26			24.5	25.9	26.6	27.3	25.6	24.3	22.4	21	19.1	22	23.2	23.3	21.8	19.9
28			19.9	22.3	23.3	24	23.1	21.9	20.2	19	17.2	19.9	20.9	21	21.1	19.3
30				18.8	20.3	21.2	21	19.9	18.4	17.1	15.6	18.1	19	19	19.1	18.7
32					17.5	18.7	19.2	18.1	16.7	15.5	14.1	16.4	17.3	17.3	17.3	17.1
34					14.5	16.3	17.2	16.6	15.3	14.1	12.8	14.9	15.7	15.7	15.8	15.5
36						14	15.2	15.2	14	12.9	11.6	13.6	14.4	14.3	14.4	14.1
38							13.3	14	12.8	11.8	10.6	12.4	13.1	13.1	13.1	12.9
40								12.5	11.8	10.8	9.6	11.4	12	12	12	11.7
42								10.8	10.9	9.9	8.8	10.4	11	11	11	10.7
44									10	9.1	8	9.5	10.1	10.1	10.1	9.8
46										8.3	7.3	8.7	9.3	9.2	9.2	8.9
48											7.6	6.6	8	8.5	8.5	8.4
50												6.1	7.3	7.8	7.7	7.4
52													6.7	7.2	7.1	6.8
54														6.1	6.6	6.2
56															6.1	5.6
58																5.4
60																4.9
62																4.4
Counterweight	75+21	75+21	75+21	75+21	75+21	75+21	75+21	75+21	75+21	75+21	75+21	75+21	75+21	75+21	75+21	75+21
Parts of line	6	6	6	5	5	4	4	4	3	3	3	3	3	2	2	2

A. Main boom working angle is 85°

Main boom 38m, Boom angle 85°																
Radius/m	Tower jib length/m															
	18	21	24	27	30	33	36	39	42	45	48	51	54	57	60	63
12	72.6	70.1														
14	63.1	61.4	59.7	57.7	55.6											
16	55.4	54.3	53.1	51.5	49.9	48.4	46.9									
18	46.8	47.7	47.5	46.3	45.1	43.8	42.4	39.8	36.2	33.8						
20	38.8	41	41.8	41.9	40.9	39.9	37	35	32	30	27.2	30.3				
22	30.8	34.1	35.7	36.6	36.9	36.1	32.7	31	28.4	26.7	24.2	27.4	27.9	25.7	22.6	
24		28.2	30.4	31.4	32	32.1	29.1	27.7	25.4	23.9	21.7	24.7	26	24.8	21.9	20.1
26			25.7	27.1	27.8	28.3	26.2	24.9	22.8	21.4	19.5	22.3	23.5	23.5	21.2	19.5
28			21.3	23.4	24.3	24.9	23.6	22.4	20.6	19.3	17.5	20.2	21.2	21.3	20.6	18.9
30				19.9	21.2	21.9	21.5	20.3	18.7	17.5	15.9	18.3	19.3	19.3	19.4	18.3
32					18.4	19.4	19.6	18.5	17	15.8	14.4	16.7	17.5	17.5	17.6	17.3
34						15.5	17	17.9	16.9	15.5	14.4	13	15.2	16	16	15.7
36							14.7	15.9	15.5	14.2	13.1	11.8	13.8	14.6	14.6	14.3
38								13.9	14.3	13.1	12	10.8	12.6	13.3	13.3	13.1
40									11.9	13	12	11	9.8	11.6	12.2	11.9
42										11.3	11.1	10.1	9	10.6	11.2	10.9
44											10.2	9.2	8.2	9.7	10.3	10
46												9.3	8.5	7.4	8.9	9.1
48													7.8	6.8	8.1	8.3
50														6.2	7.4	7.6
52															6.8	6.9
54															6.2	6.3
56																6.2
58																5.5
60																5
62																4.5
Counterweight	75+21	75+21	75+21	75+21	75+21	75+21	75+21	75+21	75+21	75+21	75+21	75+21	75+21	75+21	75+21	75+21
Parts of line	6	6	5	5	5	4	4	4	3	3	3	3	2	3	2	2

TYPICAL WORKING CONDITIONS

A. Main boom working angle is 85°

Main boom 44m, Boom angle 85°																		
Radius/m	Tower jib length/m																	
	18	21	24	27	30	33	36	39	42	45	48	51	54	57	60	63		
12	70.4																	
14	61.4	59.6	57.8	55.6														
16	53.9	52.8	51.4	49.8	48.2	46.6	44.3											
18	45.6	46.4	46.1	44.9	43.5	42.3	41.1	38.7	36									
20	39	40	40.5	40.6	39.5	38.5	37.6	35.6	32.4	30.3	27.5	28.3						
22	33	34.7	35.5	35.7	35.7	35.3	33.4	31.6	28.9	27.1	24.5	26.8	25.2	23.5				
24		29.9	31.2	31.5	31.6	31.7	29.8	28.2	25.8	24.3	22	24.9	23.8	22.4	21	19.5		
26		24	27.1	28	28.2	28.4	26.7	25.4	23.2	21.8	19.8	22.6	22.4	21.2	20	18.7		
28			22.7	24.4	25.3	25.5	24.1	22.8	21	19.7	17.8	20.5	21	19.9	18.9	17.8		
30				20.9	22.2	22.9	21.9	20.7	19	17.8	16.1	18.6	19.5	18.7	17.8	16.9		
32				17.2	19.3	20.2	20	18.8	17.3	16.1	14.6	16.9	17.8	17.4	16.7	15.9		
34					16.5	17.8	18.3	17.2	15.8	14.7	13.3	15.4	16.2	16.2	15.6	14.9		
36						15.4	16.4	15.8	14.5	13.4	12.1	14.1	14.8	14.8	14.6	14		
38							14.5	14.5	13.3	12.2	11	12.8	13.5	13.5	13.5	13.1		
40							12.5	13.4	12.2	11.2	10	11.8	12.4	12.4	12.4	12.1		
42								11.8	11.3	10.2	9.1	10.8	11.4	11.3	11.3	11.1		
44									10.4	9.4	8.3	9.9	10.5	10.4	10.4	10.1		
46									9.6	8.6	7.6	9	9.6	9.5	9.5	9.2		
48										8	6.9	8.3	8.8	8.7	8.7	8.4		
50											6.3	7.6	8.1	8	8	7.7		
52												5.8	6.9	7.5	7.4	7		
54													6.4	6.9	6.7	6.4		
56														6.3	6.2	6.1	5.8	
58															5.8	5.6	5.6	5.3
60																5.2	5.1	4.7
62																	4.6	4.3
Counterweight	75+21	75+21	75+21	75+21	75+21	75+21	75+21	75+21	75+21	75+21	75+21	75+21	75+21	75+21	75+21	75+21	75+21	75+21
Parts of line	6	5	5	5	4	4	4	4	3	3	3	2	3	2	2	2	2	2

A. Main boom working angle is 85°

Main boom 50m, Boom angle 85°																				
Radius/m	Tower jib length/m																			
	18	21	24	27	30	33	36	39	42	45	48	51	54	57	60	63				
12	63.1																			
14	57.1	54.7	52.3																	
16	51.9	50	48.1	46.1	44	41.4														
18	44.7	45.3	43.8	42	40.1	38.2	36.3	34.2												
20	38.2	39.1	38.9	37.7	36.3	34.8	33.4	31.7	30.2	28.4	26.7									
22	32.8	34	34.4	33.6	32.6	31.5	30.5	29.2	28	26.6	24.8	23.9	22.6	21.2						
24		29.6	30.4	29.8	29.2	28.4	27.7	26.7	25.8	24.6	22.2	22.5	21.3	20.1	18.9	17.7				
26		25.6	26.8	26.5	26	25.5	25	24.3	23.6	22.1	20	21	20	19	18	16.9				
28			23.7	23.5	23.2	22.9	22.6	22.1	21.3	20	18.1	19.5	18.7	17.8	17	16				
30				20.9	20.7	20.5	20.3	20	19.3	18.1	16.3	18	17.4	16.7	15.9	15.1				
32				18.4	18.5	18.4	18.3	18.1	17.6	16.4	14.8	16.6	16.1	15.5	14.9	14.2				
34					16.5	16.5	16.5	16.4	16.1	14.9	13.5	15.3	14.9	14.4	13.9	13.3				
36						14.8	14.8	14.8	14.7	13.6	12.3	14.1	13.8	13.4	13	12.5				
38							13.3	13.4	13.4	13.4	12.4	11.2	12.9	12.7	12.4	12	11.6			
40								12.1	12.1	12.1	11.4	10.2	11.8	11.7	11.4	11.2	10.8			
42									10.9	11	10.4	9.3	10.8	10.7	10.5	10.3	10			
44										9.9	10	9.6	8.5	9.9	9.9	9.7	9.5	9.3		
46											9.1	8.8	7.7	9.1	9.1	8.9	8.8	8.6		
48												8.1	7.1	8.3	8.3	8.2	8.1	8		
50													7.5	6.4	7.6	7.6	7.5	7.4		
52														5.9	7	7	6.9	6.9	6.8	
54															6.4	6.4	6.4	6.4	6.3	
56																5.9	5.9	5.8	5.8	
58																	5.4	5.4	5.4	5.3
60																		4.9	4.9	4.8
62																			4.5	4.4
Counterweight	75+21	75+21	75+21	75+21	75+21	75+21	75+21	75+21	75+21	75+21	75+21	75+21	75+21	75+21	75+21	75+21	75+21	75+21	75+21	
Parts of line	5	5	4	4	4	4	4	3	3	3	2	2	2	2	2	2	2	2	2	

TYPICAL WORKING CONDITIONS

B. Main boom working angle is 75°

Main boom 20m, Boom angle 75°																
Radius/m	Tower jib length/m															
	18	21	24	27	30	33	36	39	42	45	48	51	54	54	60	63
16	59.8															
18	51.4	51.2														
20	44.9	44.8	44.7	44.4												
22	39.8	39.7	39.6	39.3	39	38.8										
24	31.9	35	35.5	35.2	34.9	34.7	33.6									
26		29.2	31.2	31.8	31.6	31.4	29.8	28.4	26.1							
28			26.6	27.7	28.3	28.6	26.7	25.4	23.4	22						
30			22.2	24	24.8	25.3	24	22.8	21.1	19.8	18	20.9				
32				20.6	21.8	22.4	21.8	20.6	19.1	17.8	16.2	18.9	19.9	19.9		
34					19	19.9	19.8	18.7	17.3	16.1	14.7	17.1	18	18	18.2	
36					16.2	17.6	18.1	17.1	15.8	14.6	13.3	15.6	16.4	16.4	16.5	16.3
38						15.3	16.3	15.6	14.4	13.3	12	14.2	14.9	14.9	15	14.8
40							14.4	14.4	13.2	12.1	11	12.9	13.6	13.6	13.7	13.4
42							12.4	13.2	12.1	11.1	10	11.8	12.5	12.5	12.5	12.2
44								11.8	11.2	10.2	9.1	10.8	11.4	11.4	11.4	11.2
46									10.3	9.3	8.3	9.8	10.5	10.5	10.4	10.2
48									9.5	8.5	7.5	9	9.6	9.6	9.6	9.3
50										7.8	6.8	8.2	8.8	8.8	8.7	8.5
52											6.2	7.5	8.1	8.1	8	7.7
54												6.9	7.4	7.4	7.3	7
56												6.3	6.8	6.8	6.7	6.4
58													6.2	6.2	6.1	5.8
60															5.5	5.2
64															4.5	4.2
68																3.3
Counterweight	75+21	75+21	75+21	75+21	75+21	75+21	75+21	75+21	75+21	75+21	75+21	75+21	75+21	75+21	75+21	75+21
Parts of line	6	6	6	6	5	5	4	4	3	3	3	3	3	3	2	2

B. Main boom working angle is 75°

Main boom 26m, Boom angle 75°																
Radius/m	Tower jib length/m															
	18	21	24	27	30	33	36	39	42	45	48	51	54	57	60	63
18	50.4															
20	44.1	43.9	43.8													
22	39.1	38.9	38.8	38.5												
24	35	34.9	34.8	34.5	34.2	34										
26	30.4	31.6	31.5	31.2	30.9	30.7	30.6	30.3								
28		28.2	28.7	28.4	28.1	27.9	27.8	27.5	25.2							
30			25.9	26	25.7	25.6	25.5	24.6	22.7	21.3	19.4					
32			21.4	23.5	23.7	23.5	23.3	22.1	20.5	19.2	17.4	20.2				
34				20.1	21.4	21.7	21.2	20.1	18.5	17.3	15.7	18.3	19.2	19.3		
36					18.6	19.5	19.3	18.2	16.9	15.7	14.2	16.6	17.5	17.5	17.6	
38					15.7	17.2	17.7	16.7	15.4	14.2	12.9	15.1	15.9	15.9	16	15.7
40						15	16.1	15.3	14.1	13	11.7	13.8	14.5	14.5	14.5	14.3
42							14.2	14	12.9	11.8	10.7	12.6	13.3	13.2	13.3	13
44								13	11.9	10.8	9.7	11.5	12.1	12.1	12.1	11.9
46									11.6	10.9	9.9	8.8	10.5	11.1	11.1	10.8
48										10.1	9.1	8	9.6	10.2	10.1	9.9
50											8.3	7.3	8.8	9.4	9.3	9
52											7.7	6.7	8	8.6	8.5	8.2
54												6.1	7.3	7.9	7.8	7.5
56													6.7	7.2	7.1	6.8
58													6.1	6.6	6.5	6.2
60														6.1	6	5.6
62															5.4	5.1
64															5	4.6
66																4.4
68																4.1
Counterweight	75+21	75+21	75+21	75+21	75+21	75+21	75+21	75+21	75+21	75+21	75+21	75+21	75+21	75+21	75+21	75+21
Parts of line	6	6	6	5	5	5	4	4	3	3	3	3	3	3	2	2

TYPICAL WORKING CONDITIONS

A. Main boom working angle is 75°

Main boom 32m, Boom angle 75°																
Radius/m	Tower jib length/m															
	18	21	24	27	30	33	36	39	42	45	48	51	54	57	60	63
20	43.1	42.9														
22	38.3	38.1	37.9													
24	34.3	34.1	34	33.7	33.3											
26	31	30.9	30.8	30.4	30.1	29.9										
28		28.1	28	27.7	27.4	27.2	27.1	26.8								
30		25.8	25.7	25.4	25.1	24.9	24.8	24.5	24.4							
32			23.7	23.4	23.1	22.9	22.8	22.6	21.9	20.6	18.7					
34				21.6	21.4	21.2	21.1	20.9	19.8	18.6	16.9	19.5	20.1			
36				19.4	19.8	19.6	19.5	19.3	18	16.8	15.2	17.7	18.6	18.3		
38					18.1	18.3	18.2	17.8	16.4	15.2	13.8	16.1	16.9	16.9	16.9	16.6
40						16.8	17	16.3	15	13.9	12.5	14.7	15.4	15.4	15.4	15.2
42						14.5	15.8	14.9	13.7	12.6	11.4	13.4	14.1	14.1	14.1	13.8
44							13.9	13.7	12.6	11.5	10.4	12.2	12.9	12.9	12.9	12.6
46								12.7	11.6	10.6	9.4	11.2	11.8	11.8	11.8	11.5
48									11.3	10.7	9.7	8.6	10.2	10.8	10.8	10.5
50										9.9	8.9	7.8	9.3	9.9	9.9	9.6
52											8.1	7.1	8.5	9.1	9	8.8
54												7.5	6.5	7.8	8.4	8.3
56													5.9	7.2	7.7	7.6
58														6.5	7.1	6.9
60															6.5	6.3
62																5.9
64																
66																
68																
70																
Counterweight	75+21	75+21	75+21	75+21	75+21	75+21	75+21	75+21	75+21	75+21	75+21	75+21	75+21	75+21	75+21	75+21
Parts of line	6	6	6	5	5	4	4	4	3	3	3	3	3	2	2	2

A. Main boom working angle is 75°

Main boom 38m, Boom angle 75°																
Radius/m	Tower jib length/m															
	18	21	24	27	30	33	36	39	42	45	48	51	54	57	60	63
22	37.3	37.1														
24	33.4	33.2	33.1													
26	30.2	30	29.9	29.6	29.2											
28	27.5	27.4	27.3	26.9	26.6	26.4	26.2									
30		25.1	25	24.7	24.3	24.1	24	23.8								
32		22.4	23	22.7	22.4	22.2	22.1	21.8	21.8	21.5						
34			21	21	20.7	20.5	20.4	20.2	20.1	19.9	18					
36				19.3	19.2	19	18.9	18.7	18.7	18	16.3	18	18			
38					17.2	17.8	17.7	17.6	17.4	17.4	16.3	14.8	16.7	16.7	16.4	16.2
40						16	16.5	16.4	16.2	16	14.8	13.4	15.5	15.5	15.2	15.1
42							14.9	15.3	15.2	14.6	13.5	12.2	14.2	14.5	14.2	14
44								13.3	14	14.2	13.4	12.3	11.1	13	13.6	13.3
46									12.6	13	12.3	11.2	10.1	11.9	12.5	12.4
48										11.8	11.3	10.3	9.2	10.9	11.5	11.4
50											10.5	9.4	8.4	9.9	10.5	10.4
52												9.7	8.7	7.6	9.1	9.7
54													8	6.9	8.3	8.9
56														6.3	7.6	8.2
58															5.8	7
60																6.4
62																
64																
66																
68																
70																
72																
Counterweight	75+21	75+21	75+21	75+21	75+21	75+21	75+21	75+21	75+21	75+21	75+21	75+21	75+21	75+21	75+21	75+21
Parts of line	6	6	5	5	5	4	4	4	3	3	3	3	3	2	2	2

TYPICAL WORKING CONDITIONS

B. Main boom working angle is 75°

Main boom 44m, Boom angle 75°																				
Radius/m	Tower jib length/m																			
	18	21	24	27	30	33	36	39	42	45	48	51	54	57	60	63				
22	36.2																			
24	32.5	32.2																		
26	29.4	29.1	29	28.6																
28	26.8	26.6	26.4	26.1	25.7															
30	24.1	24.3	24.2	23.9	23.5	23.3	23.1													
32		22.2	22.3	22	21.6	21.4	21.3	21	21											
34			20.6	20.3	20	19.8	19.7	19.4	19.4	19.1										
36			18.3	18.8	18.6	18.4	18.2	18	17.9	17.7	17.4	17.2								
38				16.9	17.1	17.1	17	16.7	16.7	16.5	15.7	16	16							
40					15.5	15.8	15.8	15.6	15.6	15.3	14.3	14.9	14.9	14.5	14.4					
42					13.9	14.4	14.6	14.6	14.6	14.3	13	13.9	13.9	13.6	13.4	13.2				
44						13	13.4	13.5	13.6	13.1	11.8	13	13	12.7	12.5	12.3				
46							12.2	12.4	12.5	12	10.7	12.2	12.2	11.8	11.7	11.5				
48								11	11.3	11.6	10.9	9.8	11.4	11.4	11.1	11	10.7			
50									10.3	10.6	10	8.9	10.5	10.5	10.4	10.3	10.1			
52										9.7	9.2	8.1	9.7	9.7	9.6	9.5	9.3			
54											8.7	8.5	7.4	8.8	9	8.9	8.8	8.6		
56												7.8	6.8	8.1	8.3	8.2	8.2	8		
58													6.2	7.4	7.7	7.6	7.6	7.4		
60														5.6	6.8	7.1	7	7	6.8	
62															6.2	6.5	6.5	6.4	6.2	
64																5.9	5.9	5.9	5.6	
66																	5.4	5.4	5.1	
68																		4.8	4.9	4.6
70																			4.4	4.1
72																				3.7
Counterweight	75+21	75+21	75+21	75+21	75+21	75+21	75+21	75+21	75+21	75+21	75+21	75+21	75+21	75+21	75+21	75+21	75+21	75+21	75+21	75+21
Parts of line	6	5	5	5	4	4	4	4	3	3	3	2	3	2	2	2	2	2	2	2

B. Main boom working angle is 75°

Main boom 50m, Boom angle 75°																					
Radius/m	Tower jib length/m																				
	18	21	24	27	30	33	36	39	42	45	48	51	54	57	60	63					
24	31.4																				
26	28.4	28.1	28																		
28	25.9	25.6	25.5	25.1																	
30	23.7	23.5	23.4	23	22.6	22.4															
32	20.9	21.7	21.5	21.2	20.8	20.6	20.4														
34		19.4	19.9	19.6	19.2	19	18.9	18.6	18.5												
36			18	18.2	17.8	17.6	17.5	17.2	17.2	16.9											
38				16	16.5	16.5	16.4	16.3	16	16	15.7	15.6	15.2								
40					14.8	15	15.1	15.2	14.9	14.9	14.6	14.5	14.2	14.1	13.8						
42						13.6	13.8	14	14	13.9	13.7	13.5	13.2	13.2	12.9	12.7					
44							12.1	12.6	12.8	12.8	12.9	12.8	12.5	12.3	12.3	12	11.8	11.6			
46								11.3	11.7	11.8	11.9	11.8	11.4	11.5	11.5	11.2	11.1	10.8			
48									10.6	10.8	10.9	10.9	10.4	10.6	10.6	10.4	10.3	10.1			
50										9.5	9.9	10.1	10	9.5	9.8	9.8	9.6	9.5	9.3		
52											8.9	9.2	9.2	8.7	9.1	9.1	8.9	8.8	8.6		
54												8.4	8.5	7.9	8.4	8.4	8.2	8.1	7.9		
56													7.7	7.2	7.7	7.7	7.6	7.5	7.3		
58														7	6.6	7.1	7.1	7	6.9	6.8	
60															6	6.5	6.6	6.5	6.4	6.2	
62																5.9	6	5.9	5.9	5.7	
64																	5.3	5.5	5.4	5.4	5.3
66																		4.9	4.9	4.9	4.8
68																			4.5	4.5	4.4
70																			3.9	4	4
72																				3.6	3.6
76																					2.7
Counterweight	75+21	75+21	75+21	75+21	75+21	75+21	75+21	75+21	75+21	75+21	75+21	75+21	75+21	75+21	75+21	75+21	75+21	75+21	75+21	75+21	75+21
Parts of line	5	5	4	4	4	4	4	3	3	3	3	2	2	2	2	2	2	2	2	2	2

TYPICAL WORKING CONDITIONS

C.Main boom working angle is 65°

Main boom 20m, Boom angle 65°																
Radius/m	Tower jib length/m															
	18	21	24	27	30	33	36	39	42	45	48	51	54	57	60	63
22	38.1															
24	34.1	33.9														
26	30.8	30.7	30.6													
28	28.1	28	27.9	27.6												
30		25.6	25.6	25.3	24.9											
32			23.6	23.3	23	22.8	22.6									
34				21.5	21.2	21	20.9	20.7								
36				20	19.7	19.5	19.4	19.2	18.5							
38					18.3	18.2	18.1	17.9	16.8	15.6						
40						17	16.9	16.6	15.3	14.2	12.9					
42						15.5	15.8	15.2	14	12.9	11.7	13.7				
44							14.7	14	12.9	11.8	10.6	12.5	13.3	13.3		
46								12.9	11.8	10.8	9.7	11.5	12.1	12.1	12.1	
48								11.9	10.9	9.9	8.8	10.5	11.1	11.1	11.1	10.9
50									10	9	8	9.6	10.2	10.1	10.2	9.9
52										8.3	7.3	8.7	9.3	9.3	9.3	9
54										7.6	6.6	8	8.6	8.5	8.5	8.2
56											6.1	7.3	7.9	7.8	7.8	7.5
58												6.7	7.2	7.1	7.1	6.8
60												6.1	6.6	6.5	6.5	6.2
62													6.1	5.9	5.9	5.6
64														5.4	5.4	5.1
66															4.9	4.6
68															4.4	4.1
70																3.6
Counterweight	75+21	75+21	75+21	75+21	75+21	75+21	75+21	75+21	75+21	75+21	75+21	75+21	75+21	75+21	75+21	75+21
Parts of line	6	6	6	6	5	5	4	4	3	3	3	3	3	3	2	2

C.Main boom working angle is 65°

Main boom 26m, Boom angle 65°																		
Radius/m	Tower jib length/m																	
	18	21	24	27	30	33	36	39	42	45	48	51	54	57	60	63		
26	29.8	29.6																
28	27.1	26.9	26.8															
30	24.8	24.7	24.6	24.2														
32		22.7	22.7	22.3	22													
34			21	20.7	20.3	20.1												
36			19.5	19.2	18.9	18.7	18.5											
38				17.9	17.6	17.4	17.3	17	17									
40					16.4	16.2	16.1	15.9	15.8	15.6								
42					15.3	15.2	15.1	14.9	14.8	14.5	13.1							
44						14.2	14.1	13.9	13.9	13.2	11.9	13.2						
46							13.3	13.1	13.1	12	10.8	12.4	12.4					
48							12.5	12.3	12	11	9.8	11.6	11.7	11.3				
50								11.6	11.1	10.1	9	10.6	11	10.7	10.5	10.3		
52									10.2	9.2	8.2	9.7	10.3	10	9.9	9.7		
54										8.5	7.4	8.9	9.5	9.4	9.3	9.1		
56										7.8	6.8	8.1	8.7	8.6	8.6	8.4		
58											6.2	7.4	8	7.9	7.9	7.6		
60												6.8	7.3	7.2	7.2	6.9		
62												6.2	6.7	6.6	6.6	6.3		
64													6.2	6	6	5.7		
66															5.5	5.5	5.1	
68																5	5	4.6
70																	4.5	4.2
72																		3.7
Counterweight	75+21	75+21	75+21	75+21	75+21	75+21	75+21	75+21	75+21	75+21	75+21	75+21	75+21	75+21	75+21	75+21	75+21	75+21
Parts of line	6	6	6	5	5	5	4	4	3	3	3	3	3	3	3	2	2	2

TYPICAL WORKING CONDITIONS

C.Main boom working angle is 65°

Main boom 32m, Boom angle 65°																					
Radius/m	Tower jib length/m																				
	18	21	24	27	30	33	36	39	42	45	48	51	54	57	60	63					
28	26																				
30	23.8	23.6																			
32	21.9	21.8	21.6	21.3																	
34		20.1	20	19.7	19.3																
36		18.7	18.6	18.3	17.9	17.7															
38			17.3	17	16.7	16.5	16.3														
40				15.9	15.6	15.4	15.2	15													
42					14.6	14.4	14.2	14	14												
44						13.7	13.5	13.4	13.1	13.1	12.8	12.7									
46							12.6	12.5	12.3	12.3	12.1	11.9	11.6								
48								11.8	11.6	11.6	11.3	11	10.9	10.9							
50									11.1	10.9	10.9	10.7	10	10.2	10.2	9.9					
52										10.3	10.3	10.1	9.1	9.6	9.6	9.3	9.1				
54											9.7	9.4	8.3	9	9	8.7	8.6	8.3			
56												9.1	8.6	7.6	8.5	8.5	8.2	8.1	7.8		
58													7.9	6.9	8	8.1	7.7	7.6	7.4		
60														6.3	7.6	7.6	7.3	7.2	6.9		
62															5.7	6.9	7.2	6.9	6.7	6.5	
64																6.3	6.8	6.5	6.4	6.1	
66																	6.3	6.1	6	5.8	
68																		5.8	5.6	5.5	5.2
70																			5.1	5	4.7
72																				4.6	4.2
76																					3.4
Counterweight	75+21	75+21	75+21	75+21	75+21	75+21	75+21	75+21	75+21	75+21	75+21	75+21	75+21	75+21	75+21	75+21	75+21	75+21	75+21	75+21	75+21
Parts of line	6	6	6	5	5	4	4	4	4	3	3	3	3	3	2	2	2	2	2	2	2

C.Main boom working angle is 65°

Main boom 38m, Boom angle 65°																								
Radius/m	Tower jib length/m																							
	18	21	24	27	30	33	36	39	42	45	48	51	54	57	60	63								
30	22.7																							
32	20.9	20.6																						
34	19.3	19.1	19																					
36		17.7	17.6	17.3																				
38			16.5	16.4	16.1	15.7	15.4																	
40				15.3	15	14.6	14.4	14.3																
42					14	13.7	13.5	13.3	13.1															
44						13.1	12.8	12.6	12.5	12.2	12.2													
46							12	11.8	11.7	11.5	11.4	11.2												
48									11.1	11	10.8	10.7	10.5	10.3										
50										10.5	10.4	10.1	10.1	9.9	9.7	9.4	9.4							
52											9.8	9.6	9.5	9.3	9.1	8.8	8.8	8.5						
54												9	9	8.7	8.6	8.3	8.3	8	7.8					
56													8.5	8.5	8.3	8.1	7.8	7.8	7.5	7.3	7.1			
58														8	7.8	7.7	7.3	7.3	7	6.9	6.6			
60																7.4	7	6.9	6.9	6.6	6.4	6.2		
62																	6.4	6.5	6.5	6.2	6.1	5.8		
64																		5.8	6.2	6.2	5.9	5.7	5.5	
66																			5.8	5.8	5.5	5.4	5.1	
68																				5.5	5.2	5	4.8	
70																					5	4.9	4.7	4.5
72																						4.6	4.4	4.2
76																							3.7	3.7
Counterweight	75+21	75+21	75+21	75+21	75+21	75+21	75+21	75+21	75+21	75+21	75+21	75+21	75+21	75+21	75+21	75+21	75+21	75+21	75+21	75+21	75+21	75+21	75+21	
Parts of line	6	6	5	5	5	4	4	4	3	3	3	3	3	2	3	3	2	3	3	2	2	2	2	

TYPICAL WORKING CONDITIONS

C.Main boom working angle is 65°

Main boom 44m, Boom angle 65°																								
Radius/m	Tower jib length/m																							
	18	21	24	27	30	33	36	39	42	45	48	51	54	57	60	63								
32	19.7																							
34	18.2	17.9																						
36	16.9	16.7	16.5																					
38	15.7	15.5	15.4	15																				
40		14.5	14.4	14	13.6																			
42			13.4	13.1	12.7	12.5	12.3																	
44			12.6	12.3	11.9	11.7	11.5	11.3																
46				11.5	11.2	10.9	10.8	10.6	10.5															
48					10.5	10.3	10.2	9.9	9.8	9.6														
50						9.7	9.5	9.3	9.2	9	8.8													
52						9.1	9	8.8	8.7	8.5	8.3	8												
54							8.5	8.2	8.2	8	7.8	7.5	7.4											
56								7.8	7.7	7.5	7.3	7	7	6.7	6.5									
58								7.3	7.3	7.1	6.9	6.6	6.6	6.2	6.1	5.8								
60									6.9	6.7	6.5	6.2	6.2	5.9	5.7	5.4								
62										6.3	6.1	5.8	5.8	5.5	5.3	5.1								
64											5.9	5.8	5.5	5.5	5.2	5	4.7							
66												5.4	5.1	5.1	4.8	4.7	4.4							
68																4.8	4.4	4.1						
70																4.3	4.5	4.2	4.1	3.9				
72																			4	4	3.8	3.6		
76																							3.2	3.1
Counterweight	75+21	75+21	75+21	75+21	75+21	75+21	75+21	75+21	75+21	75+21	75+21	75+21	75+21	75+21	75+21	75+21	75+21	75+21	75+21	75+21	75+21	75+21	75+21	75+21
Parts of line	6	5	5	5	4	4	4	4	3	3	3	3	2	3	2	2	2	2	2	2	2	2	2	2

C.Main boom working angle is 65°

Main boom 50m, Boom angle 65°																							
Radius/m	Tower jib length/m																						
	18	21	24	27	30	33	36	39	42	45	48	51	54	57	60	63							
36	15.7	15.5																					
38	14.7	14.4	14.2																				
40	13.7	13.4	13.3	12.9																			
42		12.6	12.4	12.1	11.7																		
44			11.7	11.3	10.9	10.6																	
46			10.9	10.6	10.2	10	9.8																
48				10	9.6	9.4	9.2	8.9	8.9														
50					9	8.8	8.6	8.4	8.3	8													
52						8.5	8.3	8.1	7.9	7.8	7.5	7.4											
54							7.8	7.6	7.4	7.3	7.1	6.9	6.6										
56								7.2	7	6.9	6.7	6.5	6.2	6.1									
58									6.8	6.5	6.5	6.3	6.1	5.8	5.7	5.4							
60										6.2	6.1	5.9	5.7	5.4	5.4	5	4.9						
62											5.8	5.5	5.4	5.1	5	4.7	4.5	4.3					
64												5.2	5.2	5.1	4.7	4.7	4.4	4.2	4				
66													4.8	4.7	4.4	4.4	4.1	3.9	3.7				
68														4.4	4.1	4.1	3.8	3.7	3.4				
70																3.8	3.8	3.6	3.4	3.2			
72																	3.3	3.4	3.3	3.2	2.9		
76																			2.6	2.5			
Counterweight	75+21	75+21	75+21	75+21	75+21	75+21	75+21	75+21	75+21	75+21	75+21	75+21	75+21	75+21	75+21	75+21	75+21	75+21	75+21	75+21	75+21	75+21	75+21
Parts of line	5	5	4	4	4	4	4	3	3	3	3	2	2	2	2	2	2	2	2	2	2	2	2

TYPICAL WORKING CONDITIONS

2.Fixed jib working condition

2.1 Combinations of main boom section under fixed jib working condition

Main boom length \ Name and qty.	Boom Butt 6m	Insert section 3mA	Insert section 6mA	Insert section 12mA	Boom transition section 6m	Insert section 3mB	Insert section 6mB	Insert section 12mB	Boom top 5m
HB17	1	0	0	0	1	0	0	0	1
HB20	1	1	0	0	1	0	0	0	1
HB23	1	0	1	0	1	0	0	0	1
HB26	1	1	1	0	1	0	0	0	1
HB29	1	0	0	1	1	0	0	0	1
HB32	1	1	0	1	1	0	0	0	1
HB35	1	0	1	1	1	0	0	0	1
HB38	1	1	1	1	1	0	0	0	1
HB41	1	0	0	2	1	0	0	0	1
HB44	1	1	0	2	1	0	0	0	1
HB47	1	0	1	2	1	0	0	0	1
HB50	1	1	1	2	1	0	0	0	1
HB53	1	0	0	2	1	0	0	1	1
HB56	1	1	0	2	1	0	0	1	1
HB59	1	0	1	2	1	0	0	1	1
HB62	1	1	1	2	1	0	0	1	1
HB65	1	1	1	2	1	1	0	1	1

2.1 Combinations of jib section under fixed jib working condition

Jib length \ Name and qty.	Tower jib butt 1.5m	Insert section 3mB	Insert section 6mB	Insert section 12mB	Tower jib transition section 4.5m	Insert section 3mC	Insert section 6mC	Insert section 12mC	Tower jib top section 3m
F9	1	0	0	0	1	0	0	0	1
F12	1	1	0	0	1	0	0	0	1
F15	1	1	0	0	1	1	0	0	1
F18	1	1	1	0	1	0	0	0	1
F21	1	1	1	0	1	1	0	0	1
F24	1	1	1	0	1	0	1	0	1
F27	1	1	0	1	1	1	0	0	1
F30	1	1	1	1	1	0	0	0	1

Notes:

1. Tower jib rear pendants must be installed for boom sections; tower jib guide pulley must be installed for boom top section.
2. When the combination length of the main boom and tower jib exceeds 71m, a wedge block is recommended to be used to raise the boom (jib).

TYPICAL WORKING CONDITIONS

2.2 Boom raising table of fixed jib working condition (HF) (counterweight combination 75t+21t)

Main boom Tower jib	HB17	HB20	HB23	HB26	HB29	HB32	HB35	HB38	HB41	HB44	HB47	HB50	HB53	HB56	HB59	HB62	HB65
F9	●	●	●	●	●	●	●	●	●	●	●	●	●	●	●	●	●
F12	●	●	●	●	●	●	●	●	●	●	●	●	●	●	●	●	×
F15	●	●	●	●	●	●	●	●	●	●	●	●	●	●	●	●	×
F18	●	●	●	●	●	●	●	●	●	●	●	●	●	●	●	×	×
F21	●	●	●	●	●	●	●	●	●	●	●	●	●	×	×	×	×
F24	●	●	●	●	●	●	●	●	●	●	●	●	●	×	×	×	×
F27	●	●	●	●	●	●	●	●	●	●	●	●	×	×	×	×	×
F30	●	●	●	●	●	●	●	●	●	●	●	×	×	×	×	×	×

Notes:

- When raising boom, place the drive roller of crawler tracks at the rear of the crane body.
- “●” —means boom raising is allowable, “×” —means boom raising is not allowable, this working condition cannot be used.
- Tower jib rear pendants must be installed for boom sections; tower jib guide pulley must be installed for boom top section.
- For the combinations which the length of boom plus the length of jib exceeds 71m, if it is available, a wedge block is recommended to be used to ensure the safety of boom (jib) raising and lowering.

3.5 Partial lifting performance of fixed jib working condition (HF)

Notes:

- The actual lifting weight is the remained weight after the weights of hook, slings and wire ropes reeved on hook and boom (jib) head are subtracted from the rated lifting load in table.
- The rated loads in the table are the lifted values when the loads are lifted slowly and stably in non-travelling state on plane and solid ground with the gradient no more than 1%.
- The load values given in the table are the load hanging freely without consideration of the influence of wind load to the lifted load, the ground condition, gradient, operation speed and may other factors negatively impact on the safe operation of the crane. Thus, the operator is responsible for the current situation judgment, reducing the lifted load correspondingly and reducing the speed.
- When the combination length of the main boom and jib exceeds 71m, a wedge block is recommended to be used to raise the boom (jib).

3.4 Working radius of fixed jib working condition (HF)

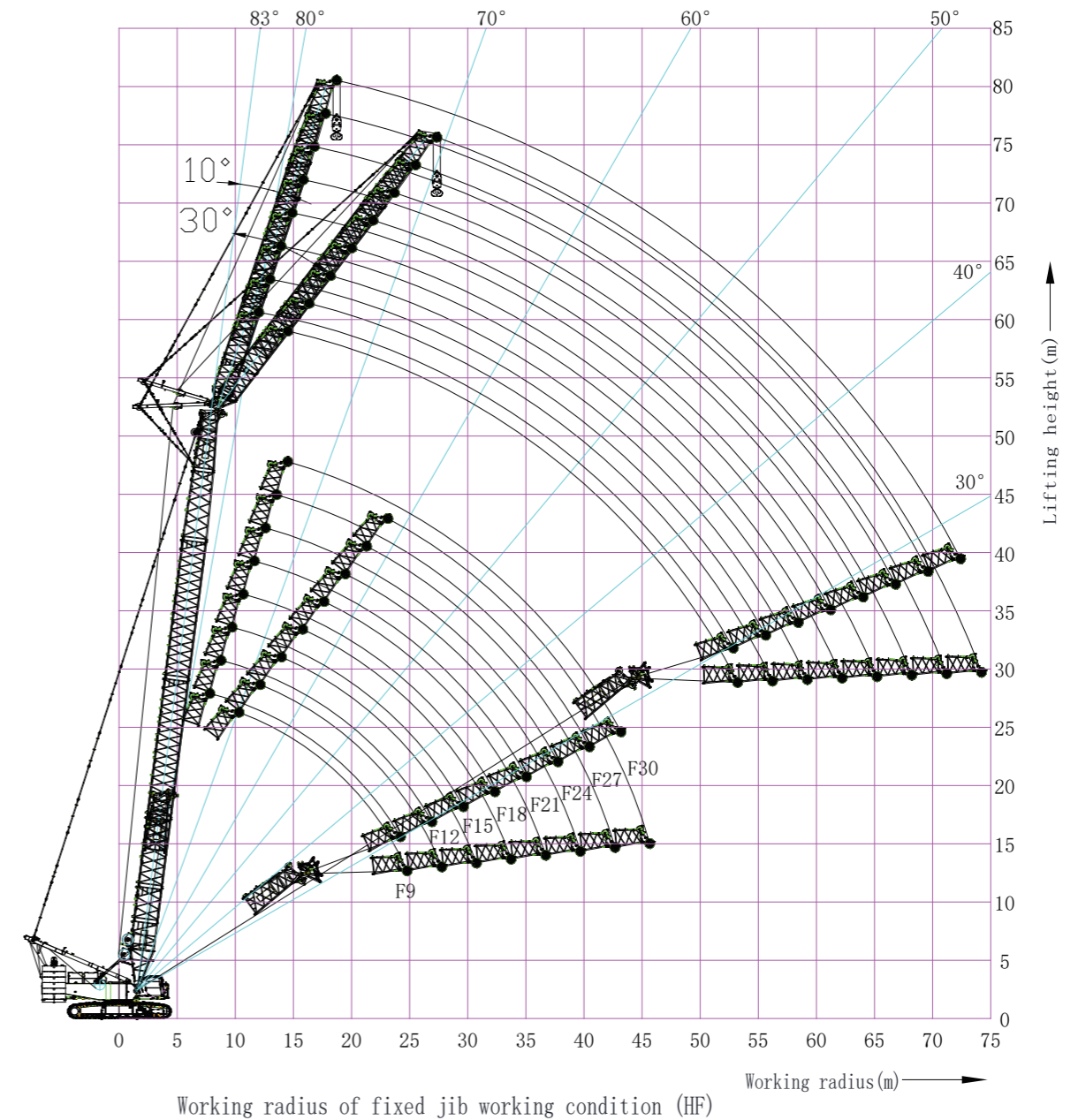

TYPICAL WORKING CONDITIONS

A. Off-set angle of main boom and jib is 10°

10° off-set angle, Main boom 17m								
Radius/m	Jib length/m							
	9	12	15	18	21	24	27	30
7	75							
8	69.8	60.4						
9	65.3	56.2	49.2					
10	61.1	52.5	46	41.2				
12	52.3	46.4	40.5	36.2	33.4	31.4	29.8	
14	45.7	41.6	36.2	32.3	29.7	27.9	26.4	24.4
16	40.6	37.6	32.6	29	26.7	25	23.6	21.8
18	36.5	34.1	29.7	26.4	24.1	22.6	21.2	19.7
20	33.2	30.8	27.3	24.1	22	20.6	19.3	17.8
22	30.5	28.1	25.2	22.2	20.2	18.9	17.6	16.3
24	28.3	25.9	23.4	20.6	18.7	17.4	16.2	14.9
26		24	21.9	19.2	17.4	16.1	14.9	13.7
28		22.4	20.3	17.9	16.2	15	13.8	12.7
30			18.9	16.8	15.1	14	12.8	11.8
32				15.9	14.2	13.1	12	10.9
34				15.1	13.4	12.3	11.2	10.2
36					12.7	11.6	10.5	9.5
38						11	9.9	8.9
40							9.3	8.4
42							8.8	7.9
44								7.4

A. Off-set angle of main boom and jib is 10°

10° off-set angle, Main boom 23m								
Radius/m	Jib length/m							
	9	12	15	18	21	24	27	30
8	51.2	43.7						
9	48.7	41.3	35.5					
10	46.4	39.1	33.6	29.5				
12	42.4	35.4	30.2	26.5	24.1	22.4		
14	38.9	32.3	27.5	24	21.8	20.2	18.9	17.2
16	36	29.6	25.1	21.9	19.8	18.3	17.1	15.5
18	33.5	27.3	23.1	20.1	18.1	16.7	15.5	14.1
20	31.4	25.4	21.4	18.5	16.6	15.3	14.2	12.8
22	29.5	23.7	19.9	17.2	15.4	14.1	13	11.7
24	27.9	22.2	18.6	16	14.3	13.1	12	10.8
26	26.6	20.9	17.4	14.9	13.3	12.1	11.1	9.9
28	25.4	19.8	16.4	14	12.4	11.3	10.3	9.2
30	23.5	18.9	15.5	13.2	11.7	10.6	9.6	8.5
32		18	14.7	12.5	11	9.9	8.9	7.9
34			14.1	11.8	10.3	9.3	8.3	7.4
36			13.4	11.2	9.7	8.8	7.8	6.9
38				10.6	9.2	8.2	7.2	6.4
40					8.7	7.7	6.8	5.9
42					8.2	7.3	6.3	5.5
44						6.9	5.9	5.1
46							5.6	4.8
48								4.4
50								4.2

TYPICAL WORKING CONDITIONS

A. Off-set angle of main boom and jib is 10°

10° off-set angle, Main boom 29m								
Radius/m	Jib length/m							
	9	12	15	18	21	24	27	30
8	62.4							
9	60.2	50.8						
10	58.2	48.8	41.5					
12	54.5	45.3	38.3	33.3	30	27.8		
14	51.3	42.3	35.7	30.9	27.8	25.6	23.9	21.6
16	48.6	39.7	33.3	28.8	25.8	23.8	22.1	19.9
18	46	37.3	31.2	26.9	24.1	22.1	20.5	18.5
20	43	35	29.2	25.1	22.5	20.6	19.1	17.2
22	37.5	33	27.4	23.6	21	19.2	17.7	16
24	33	31.2	25.9	22.2	19.7	18	16.6	14.9
26	29.3	29.5	24.5	20.9	18.6	16.9	15.5	13.9
28	26.2	26.4	23.2	19.8	17.5	15.9	14.5	13.1
30	23.5	23.7	22.1	18.8	16.6	15	13.7	12.3
32	21.2	21.4	21.1	17.8	15.7	14.2	12.9	11.5
34	19.1	19.4	19.7	17	14.9	13.5	12.2	10.9
36		17.6	17.9	16.2	14.2	12.8	11.5	10.3
38		15.9	16.3	15.6	13.6	12.2	10.9	9.7
40			14.9	14.9	13	11.6	10.4	9.2
42				13.7	12.4	11.1	9.9	8.7
44				12.5	12	10.6	9.4	8.3
46					11.5	10.2	9	7.9
48						9.8	8.5	7.5
50						9.4	8.1	7.1
52							7.8	6.7
54								6.4

A. Off-set angle of main boom and jib is 10°

10° off-set angle, Main boom 35m								
Radius/m	Jib length/m							
	9	12	15	18	21	24	27	30
9	68.2							
10	66.5	55.7	47					
12	63.3	52.6	44.2	38.2	34.3			
14	60.1	49.8	41.7	36	32.2	29.6	27.6	
16	55.2	45.8	38.8	33.9	30.4	27.8	25.8	23.2
18	49.8	42.2	35.8	31.2	28.1	25.8	23.9	21.7
20	42.8	39.2	33.2	29	26	23.8	22	20
22	37.2	36.5	31	27	24.2	22.2	20.4	18.6
24	32.7	32.9	29	25.2	22.6	20.7	19	17.3
26	29	29.2	27.3	23.7	21.2	19.4	17.8	16.1
28	25.9	26.1	25.7	22.3	19.9	18.2	16.7	15.1
30	23.3	23.4	23.7	21.1	18.8	17.2	15.7	14.2
32	21	21.1	21.4	20	17.8	16.2	14.8	13.3
34	19	19.1	19.4	19	16.9	15.4	14	12.6
36	17.2	17.3	17.6	17.7	16.1	14.6	13.2	11.9
38	15.6	15.7	16	16.1	15.3	13.9	12.6	11.3
40	14.1	14.3	14.6	14.7	14.6	13.2	11.9	10.7
42		13	13.3	13.4	13.6	12.6	11.4	10.2
44			12.1	12.2	12.4	12.1	10.8	9.7
46			11.1	11.2	11.4	11.6	10.3	9.2
48				10.2	10.4	10.6	9.9	8.8
50					9.5	9.7	9.5	8.4
52					8.6	8.9	8.9	8
54						8.1	8.1	7.7
56							7.4	7.4
58							6.7	6.7
60								6.1

A. Off-set angle of main boom and jib is 10°

10° off-set angle, Main boom 41m								
Radius/m	Jib length/m							
	9	12	15	18	21	24	27	30
9	73.7							
10	71.1	59.4						
12	64.8	53.9	45.5	39.6				
14	59.4	49.4	41.7	36.3	32.6	29.9	27.8	
16	54.9	45.5	38.5	33.5	30	27.5	25.5	23.1
18	49.5	42.2	35.7	31	27.8	25.4	23.5	21.3
20	42.5	39.3	33.2	28.9	25.8	23.6	21.8	19.7
22	36.9	36.8	31.1	27	24.1	22.1	20.3	18.4
24	32.4	32.6	29.2	25.3	22.6	20.7	19	17.1
26	28.7	28.9	27.5	23.9	21.3	19.4	17.8	16
28	25.6	25.7	26	22.5	20.1	18.3	16.7	15.1
30	23	23.1	23.4	21.3	19	17.3	15.8	14.2
32	20.7	20.8	21	20.3	18	16.4	14.9	13.4
34	18.7	18.7	19	19.1	17.1	15.5	14.1	12.6
36	16.9	17	17.3	17.3	16.3	14.8	13.4	12
38	15.3	15.4	15.7	15.7	15.6	14.1	12.7	11.4
40	13.9	14	14.3	14.3	14.5	13.4	12.1	10.8
42	12.6	12.7	13	13	13.2	12.8	11.5	10.3
44	11.5	11.6	11.8	11.9	12	12.2	11	9.8
46	10.4	10.5	10.8	10.8	11	11.2	10.5	9.3
48		9.5	9.8	9.8	10	10.2	10.1	8.9
50			8.9	8.9	9.1	9.3	9.3	8.5
52			8.1	8.1	8.3	8.5	8.5	8.2
54				7.3	7.5	7.7	7.7	7.7
56					6.8	7	7	7
58						6.4	6.3	6.3
60						5.7	5.7	5.7
62							5.1	5.1
64								4.5
66								4

A. Off-set angle of main boom and jib is 10°

10° off-set angle, Main boom 47m								
Radius/m	Jib length/m							
	9	12	15	18	21	24	27	30
10	69.2							
12	63.5	53	44.7	38.8				
14	58.7	48.8	41.2	35.8	32	29.3		
16	54.5	45.3	38.2	33.1	29.6	27.1	25.1	22.6
18	49.2	42.1	35.6	30.9	27.6	25.2	23.3	21
20	42.1	39.4	33.3	28.8	25.7	23.5	21.7	19.5
22	36.6	36.7	31.2	27.1	24.1	22	20.2	18.2
24	32.1	32.2	29.4	25.5	22.7	20.7	19	17.1
26	28.4	28.5	27.8	24	21.4	19.5	17.8	16
28	25.3	25.4	25.7	22.8	20.2	18.4	16.8	15.1
30	22.6	22.7	23	21.6	19.2	17.4	15.9	14.2
32	20.3	20.4	20.7	20.6	18.2	16.5	15	13.5
34	18.3	18.4	18.6	18.7	17.4	15.7	14.3	12.8
36	16.5	16.6	16.9	16.9	16.6	15	13.5	12.1
38	15	15	15.3	15.3	15.5	14.3	12.9	11.5
40	13.6	13.6	13.9	13.9	14	13.7	12.3	10.9
42	12.3	12.4	12.6	12.6	12.8	13	11.7	10.4
44	11.2	11.2	11.4	11.5	11.6	11.8	11.2	10
46	10.1	10.2	10.4	10.4	10.5	10.7	10.7	9.5
48	9.2	9.2	9.4	9.4	9.6	9.8	9.7	9.1
50	8.3	8.3	8.5	8.6	8.7	8.9	8.8	8.7
52		7.5	7.7	7.7	7.9	8.1	8	8
54		6.7	7	7	7.1	7.3	7.3	7.2
56			6.3	6.3	6.4	6.6	6.6	6.5
58				5.6	5.7	6	5.9	5.9
60				5	5.1	5.3	5.3	5.2
62					4.5	4.8	4.7	4.7
64						4.2	4.2	4.1
66							3.7	3.6
68							3.2	3.1
70								2.7

A. Off-set angle of main boom and jib is 10°

10° off-set angle, Main boom 53m							
Radius/m	Jib length/m						
	9	12	15	18	21	24	27
10	53.6						
12	51.5	45.2	39.9				
14	49.4	43.3	37.7	33.1	30		
16	47.6	41.3	35.7	31.3	28.3	25.8	23.8
18	45.9	39.4	33.9	29.7	26.5	24.1	22.2
20	42	37.6	32.2	27.9	24.8	22.6	20.8
22	36.5	35.9	30.4	26.3	23.4	21.3	19.5
24	32	32.1	28.7	24.8	22.1	20.1	18.4
26	28.2	28.3	27.2	23.5	20.9	19	17.3
28	25.1	25.2	25.5	22.3	19.8	18	16.4
30	22.5	22.5	22.8	21.3	18.8	17.1	15.5
32	20.2	20.2	20.5	20.3	17.9	16.3	14.7
34	18.2	18.2	18.4	18.5	17.1	15.5	14
36	16.4	16.4	16.7	16.7	16.4	14.8	13.3
38	14.8	14.9	15.1	15.1	15.2	14.1	12.7
40	13.4	13.4	13.7	13.7	13.8	13.5	12.2
42	12.2	12.2	12.4	12.4	12.5	12.7	11.6
44	11	11	11.2	11.2	11.4	11.5	11.1
46	10	10	10.2	10.2	10.3	10.5	10.4
48	9.1	9.1	9.3	9.2	9.3	9.5	9.5
50	8.2	8.2	8.4	8.4	8.5	8.6	8.6
52	7.4	7.4	7.6	7.5	7.6	7.8	7.8
54	6.6	6.6	6.8	6.8	6.9	7.1	7
56	5.9	5.9	6.1	6.1	6.2	6.4	6.3
58		5.3	5.5	5.4	5.5	5.7	5.6
60			4.8	4.8	4.9	5.1	5
62			4.3	4.2	4.4	4.5	4.5
64				3.7	3.8	4	3.9
66					3.3	3.5	3.4
68					2.8	3	2.9
70						2.5	2.5
72							2

A. Off-set angle of main boom and jib is 10°

10° off-set angle, Main boom 59m					Main boom 65m
Radius/m	Jib length/m				Jib length/m
	9	9	15	18	9
12	48.4	42.7			44.4
14	46.8	41.1	36.2	32.4	43
16	45.1	39.5	34.8	31.1	41.6
18	43.6	38.1	33.5	29.4	40.4
20	40.9	36.8	32.1	27.7	39.2
22	36.1	35.5	30.3	26.2	35.1
24	31.6	31.7	28.8	24.8	31.2
26	27.9	28	27.4	23.6	27.5
28	24.7	24.8	25.1	22.5	24.3
30	22.1	22.1	22.4	21.4	21.7
32	19.8	19.8	20.1	20.1	19.3
34	17.8	17.8	18	18.1	17.3
36	16	16	16.2	16.3	15.6
38	14.4	14.4	14.7	14.7	14
40	13	13	13.2	13.2	12.6
42	11.8	11.8	12	12	11.4
44	10.7	10.6	10.8	10.8	10.2
46	9.6	9.6	9.8	9.8	9.2
48	8.7	8.6	8.8	8.8	8.2
50	7.8	7.8	8	7.9	7.4
52	7	7	7.2	7.1	6.6
54	6.3	6.2	6.4	6.4	5.8
56	5.6	5.5	5.7	5.7	5.2
58	4.9	4.9	5.1	5	4.5
60	4.3	4.3	4.5	4.4	3.9
62		3.7	3.9	3.8	3.4
64		3.2	3.4	3.3	2.8
66			2.9	2.8	2.3
68				2.3	

B. Off-set angle between main boom and jib is 30

30° off-set angle, Main boom 17m								
Radius/m	Jib length/m							
	9	12	15	18	21	24	27	30
10	37.6							
12	33.9	31.1						
14	31	28.1	25.6					
16	28.6	25.8	23.3	21.3				
18	26.7	23.8	21.4	19.5	18.3	16.9		
20	25.1	22.2	19.8	18	16.9	15.8	14.5	
22	23.8	20.8	18.5	16.7	15.6	14.8	13.6	12.3
24	23	19.7	17.3	15.6	14.4	13.8	12.7	11.5
26		18.8	16.4	14.6	13.5	12.8	11.9	10.8
28			15.6	13.7	12.6	11.9	11.2	10.2
30			15	13	11.9	11.2	10.4	9.5
32				12.4	11.2	10.5	9.7	8.8
34					10.7	9.9	9.1	8.2
36						9.4	8.6	7.7
38						9	8.1	7.2
40							7.7	6.8
42								6.4
44								6.1

B. Off-set angle between main boom and jib is 30

30° off-set angle, Main boom 23m								
Radius/m	Jib length/m							
	9	12	15	18	21	24	27	30
10	30.6							
12	29	23.4						
14	27.6	22.1	18.4					
16	26.4	21	17.4	14.9				
18	25.3	19.9	16.5	14.1	12.4			
20	24.3	19	15.7	13.3	11.7	10.6		
22	23.5	18.2	15	12.6	11.1	10	8.9	7.9
24	22.9	17.5	14.3	12	10.5	9.4	8.4	7.4
26	22.3	16.9	13.7	11.5	10	8.9	7.9	7
28	22	16.4	13.2	11	9.5	8.5	7.5	6.5
30		16.1	12.8	10.5	9.1	8.1	7.1	6.2
32			12.4	10.2	8.7	7.7	6.7	5.8
34			12.2	9.8	8.4	7.4	6.4	5.5
36				9.6	8.1	7.1	6.1	5.2
38					7.8	6.8	5.8	4.9
40					7.6	6.5	5.5	4.7
42						6.3	5.3	4.4
44							5.1	4.2
46							5	4.1
48								3.9

TYPICAL WORKING CONDITIONS

B. Off-set angle between main boom and jib is 30

30° off-set angle, Main boom 29m								
Radius/m	Jib length/m							
	9	12	15	18	21	24	27	30
8	35.7	28.5						
9	34.7	27.5	22.6					
10	32.6	26.6	21.8	18.5				
12	30.8	25.6	21	17.8	15.5			
14	29.2	24.7	20.2	17.1	15	13.4		
16	27.8	23.9	19.5	16.4	14.3	12.9	11.5	
18	26.6	23	18.8	15.8	13.8	12.3	11	9.7
20	25.5	21.9	18.2	15.2	13.2	11.8	10.6	9.3
22	24.6	21	17.6	14.7	12.7	11.4	10.1	8.9
24	23.7	20.2	17.1	14.2	12.3	10.9	9.7	8.5
26	21.3	19.5	16.6	13.8	11.9	10.5	9.3	8.1
28		18.9	16	13.4	11.5	10.1	8.9	7.8
30		17.7	15.5	13	11.1	9.8	8.6	7.5
32			15.1	12.7	10.8	9.5	8.3	7.2
34				12.5	10.5	9.2	8	6.9
36				12.1	10.3	8.9	7.7	6.6
38					10.1	8.7	7.5	6.4
40						8.5	7.3	6.2
42						8.4	7.1	6
44							6.9	5.8
46								5.6
48								5.5
50								
52								
54								

B. Off-set angle between main boom and jib is 30

30° off-set angle, Main boom 35m								
Radius/m	Jib length/m							
	9	12	15	18	21	24	27	30
12	38.4							
14	36.1	31.3						
16	34	29.9	24.9					
18	32.3	28.2	24.3	20.4	17.8			
20	30.7	26.7	23.2	19.9	17.3	15.4		
22	29.3	25.4	22	19.4	16.8	15	13.4	
24	28.1	24.2	20.9	18.4	16.4	14.6	13	11.4
26	27	23.2	19.9	17.5	15.8	14.2	12.6	11.1
28	26.1	22.3	19.1	16.7	15	13.8	12.3	10.8
30	23.6	21.4	18.3	15.9	14.3	13.3	11.9	10.4
32	21.2	20.7	17.6	15.3	13.7	12.6	11.5	10.1
34	19.2	19.5	17	14.7	13.1	12.1	11	9.7
36	17.3	17.7	16.4	14.1	12.6	11.5	10.5	9.2
38		16	15.9	13.6	12.1	11.1	10	8.8
40		14.5	15	13.2	11.6	10.6	9.5	8.4
42			13.6	12.8	11.2	10.2	9.1	8
44				12.5	10.9	9.8	8.7	7.6
46				11.4	10.5	9.5	8.4	7.3
48					10.3	9.2	8.1	7
50						8.9	7.8	6.7
52						8.7	7.5	6.4
54							7.3	6.2
56								6
58								5.8

TYPICAL WORKING CONDITIONS

B. Off-set angle between main boom and jib is 30

30° off-set angle, Main boom 41m								
Radius/m	Jib length/m							
	9	12	15	18	21	24	27	30
12	39.8							
14	37.6	32.7						
16	35.6	30.9	26.7					
18	33.9	29.2	25.3	22.3				
20	32.3	27.8	24	21.1	19.2			
22	30.9	26.5	22.8	20	18.1	16.7	15	
24	29.7	25.4	21.8	19.1	17.2	16	14.6	12.8
26	28.6	24.3	20.8	18.2	16.4	15.1	14	12.5
28	26.1	23.4	20	17.4	15.6	14.4	13.3	11.9
30	23.4	22.6	19.2	16.7	14.9	13.7	12.6	11.2
32	21	21.4	18.5	16	14.3	13.1	12	10.7
34	19	19.3	17.9	15.4	13.7	12.6	11.5	10.1
36	17.1	17.4	17.3	14.9	13.2	12	10.9	9.6
38	15.5	15.8	16.2	14.4	12.7	11.6	10.5	9.2
40	14	14.3	14.7	13.9	12.2	11.1	10	8.8
42	12.7	13	13.4	13.5	11.8	10.7	9.6	8.4
44		11.7	12.2	12.4	11.5	10.3	9.2	8
46			11	11.2	11.1	10	8.9	7.7
48			10	10.2	10.5	9.7	8.6	7.4
50				9.2	9.5	9.4	8.3	7.1
52					8.6	9	8	6.8
54					7.8	8.2	7.7	6.6
56						7.4	7.5	6.3
58							6.8	6.1
60							6	5.9
62								5.5

B. Off-set angle between main boom and jib is 30

30° off-set angle, Main boom 47m								
Radius/m	Jib length/m							
	9	12	15	18	21	24	27	30
12	40.9							
14	38.8	33.5						
16	36.9	31.8	27.4					
18	35.2	30.2	26	22.7				
20	33.7	28.8	24.7	21.5	19.6			
22	32.3	27.6	23.6	20.5	18.6	16.9		
24	31.1	26.4	22.6	19.6	17.7	16.3	14.6	
26	28.9	25.4	21.6	18.7	16.9	15.6	14	12.5
28	25.7	24.5	20.8	17.9	16.2	14.9	13.5	12
30	23	23.3	20	17.2	15.5	14.2	13	11.5
32	20.6	20.9	19.3	16.6	14.9	13.6	12.4	10.9
34	18.6	18.8	18.7	16	14.3	13.1	11.8	10.4
36	16.7	17	17.5	15.4	13.8	12.5	11.3	10
38	15.1	15.4	15.8	14.9	13.3	12.1	10.9	9.5
40	13.7	13.9	14.3	14.5	12.8	11.6	10.4	9.1
42	12.4	12.6	13	13.2	12.4	11.2	10	8.7
44	11.2	11.4	11.8	12	12	10.8	9.6	8.4
46	10.1	10.3	10.7	10.8	11.1	10.5	9.3	8
48		9.3	9.6	9.8	10.1	10.1	9	7.7
50		8.3	8.7	8.9	9.1	9.5	8.7	7.4
52			7.8	8	8.3	8.6	8.4	7.2
54				7.1	7.4	7.8	7.9	6.9
56				6.4	6.7	7	7.1	6.7
58					5.9	6.3	6.4	6.4
60						5.6	5.7	5.8
62							5	5.1
64							4.4	4.5
66								3.8

TYPICAL WORKING CONDITIONS

B. Off-set angle between main boom and jib is 30

30° off-set angle, Main boom 53m							
Radius/m	Jib length/m						
	9	12	15	18	21	24	27
14	38.1						
16	36.9	30.3	25.6				
18	35.8	29.3	24.7	21.2			
20	34.6	28.4	23.9	20.5	18.1		
22	33.3	27.6	23.2	19.8	17.5	15.7	
24	32.1	26.8	22.5	19.2	16.9	15.2	13.7
26	29	26.1	21.8	18.6	16.4	14.7	13.2
28	25.8	25.4	21.3	18.1	15.9	14.2	12.7
30	23	23.4	20.7	17.6	15.4	13.8	12.3
32	20.7	21	20.2	17.2	15	13.4	11.9
34	18.6	18.9	19.3	16.7	14.6	13	11.6
36	16.8	17	17.5	16.1	14.2	12.6	11.2
38	15.2	15.4	15.8	15.6	13.7	12.2	10.8
40	13.7	13.9	14.3	14.5	13.3	11.9	10.5
42	12.4	12.6	13	13.2	12.9	11.5	10.1
44	11.3	11.4	11.8	11.9	12.2	11.2	9.8
46	10.2	10.3	10.7	10.8	11.1	10.9	9.5
48	9.2	9.3	9.7	9.8	10.1	10.4	9.3
50	8.3	8.4	8.7	8.8	9.1	9.4	9
52		7.6	7.9	8	8.2	8.6	8.6
54		6.8	7.1	7.2	7.4	7.7	7.8
56			6.3	6.4	6.7	7	7
58				5.7	5.9	6.3	6.3
60				5	5.3	5.6	5.6
62					4.6	4.9	5
64						4.3	4.4
66						3.8	3.8
68							3.3

B. Off-set angle between main boom and jib is 30

30° off-set angle, Main boom 59m					Main boom 65m
Radius/m	Jib length/m				Jib length/m
	9	12	15	18	9
14	37.5				34.9
16	36.5	30			34
18	35.5	29.1	24.5		33.3
20	34.6	28.3	23.7	20.3	32.5
22	33.7	27.5	23	19.7	31.8
24	32.5	26.8	22.4	19.1	31.2
26	28.7	26.1	21.8	18.6	28.4
28	25.5	25.5	21.3	18.1	25.1
30	22.7	23.1	20.8	17.6	22.4
32	20.4	20.6	20.2	17.1	20
34	18.3	18.5	19	16.6	17.9
36	16.5	16.7	17.1	16.1	16.1
38	14.8	15.1	15.5	15.7	14.5
40	13.4	13.6	14	14.2	13
42	12.1	12.3	12.7	12.8	11.7
44	10.9	11.1	11.4	11.6	10.5
46	9.9	10	10.3	10.5	9.5
48	8.9	9	9.3	9.5	8.5
50	8	8.1	8.4	8.5	7.6
52	7.1	7.2	7.5	7.6	6.8
54	6.4	6.5	6.7	6.8	6
56	5.6	5.7	6	6.1	5.3
58		5	5.3	5.4	4.6
60			4.7	4.7	4
62			4.1	4.1	
64				3.5	

PARAMETERS OF MAIN TRANSPORTING COMPONENTS

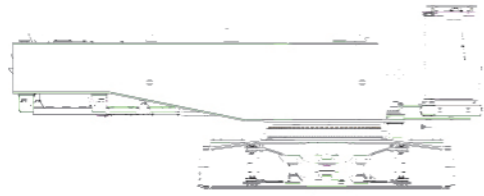

Basic machine transport plan A	× 1
L	12.30m
W	3.00m
H	3.32m
W	38.1t

With main luffing winch and wire rope, cab, mast and sheave block, etc., without turntable counterweight self-assembly and disassembly device, tower jib single top winch and etc.

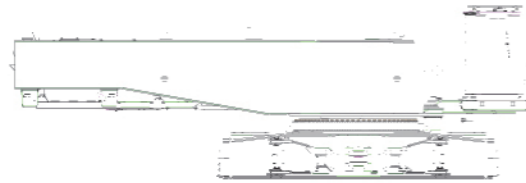

Basic machine transport plan B (optional)	× 1
L	10.08m
W	3.00m
H	3.30m
W	32.9t

Without main luffing winch and wire rope, mast, luffing sheave block, turntable counterweight self-assembly and disassembly device, tower jib single top winch and other optional devices etc.



Mast independent transport part (optional)	× 1
L	9.98m
W	1.94m
H	1.32m
W	5.2t

Include main luffing winch and wire rope, mast, luffing sheave block and some boom pendants, this is used when it is not transported with basic machine

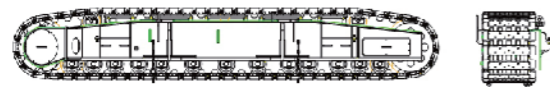

Left track frame	× 1
L	8.85m
W	1.58m
H	1.35m
W	20.3t



Right track frame	× 1
L	8.85m
W	1.58m
H	1.35m
W	20.3t

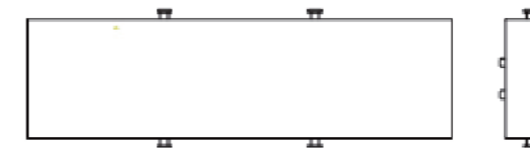

Car-body counterweight slab	× 2
L	4.80m
W	1.55m
H	0.45m
W	10.5t

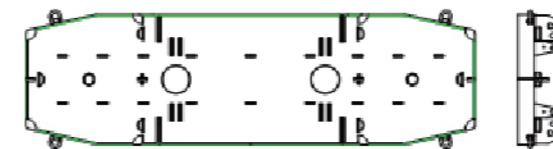

Turntable counterweight tray	× 1
L	6.74m
W	2.25m
H	0.64m
W	15.0t

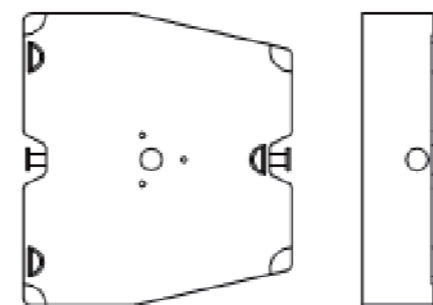

Turntable counterweight slab	× 12
L	1.80m
W	2.00m
H	0.57m
W	5.0t

PARAMETERS OF MAIN TRANSPORTING COMPONENTS

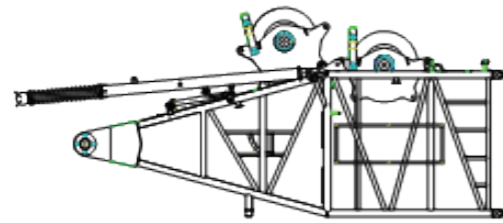

Boom base	× 1
L	7.08m
W	2.96m
H	3.03m
W	9.60t
Including main winch, aux. winch and wire rope, boom pendants, tower jib pendants, backstop stop device and etc.	

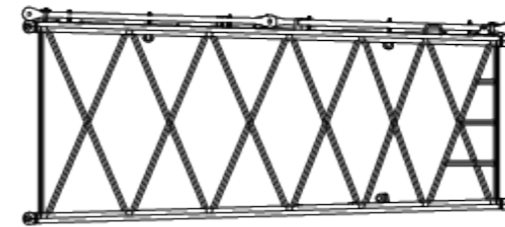

Boom 6m transition section	× 1
L	6.17m
W	2.5m
H	2.26m
W	1.5t
Including boom pendant and tower jib pendants	

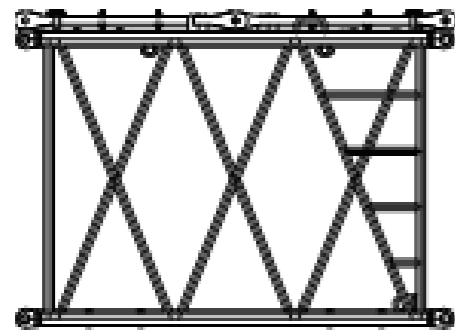

Boom 3m insert A	× 1
L	3.17m
W	2.5m
H	2.26m
W	0.9t
Including boom pendant and tower jib pendants	

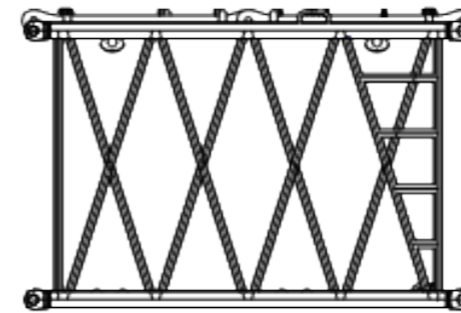

Boom 3m insert B	× 1
L	3.13m
W	2.12m
H	1.89m
W	0.6t
Including boom pendant and tower jib pendants	

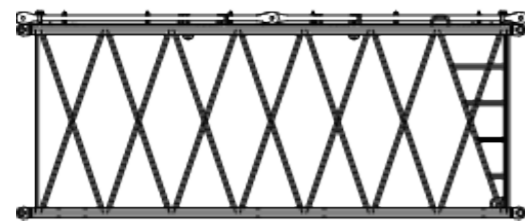

Boom 6m insert A	× 1
L	6.17m
W	2.5m
H	2.26m
W	1.5t
Including boom pendant and tower jib pendants	

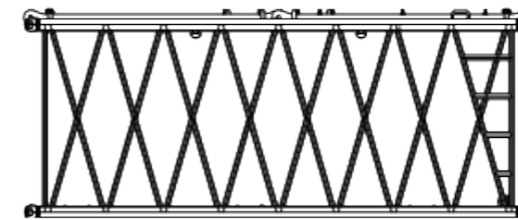

Boom 6m insert B	× 1
L	6.13m
W	2.12m
H	1.89m
W	1.1t
Including boom pendant and tower jib pendants	

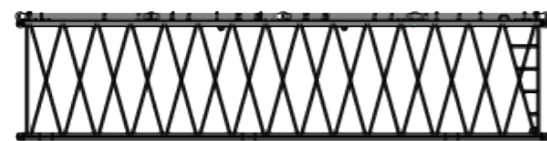

Boom 12m insert A	× 2
L	12.18m
W	2.5m
H	2.26m
W	2.5t
Including boom pendant and tower jib pendants	

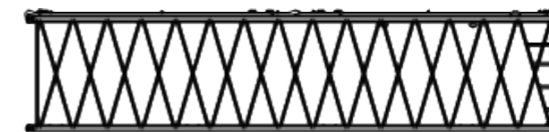

Boom 12m insert B	× 2
L	12.13m
W	2.12m
H	1.89m
W	2.3t
Including boom pendant and tower jib pendants	

PARAMETERS OF MAIN TRANSPORTING COMPONENTS

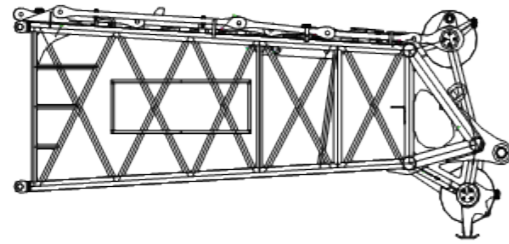

Boom top	× 1
L	5.58m
W	2.2m
H	2.47m
W	3.2t
Including boom pendant and tower jib pendants	

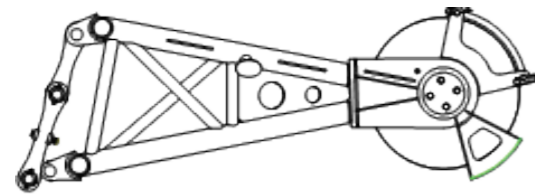

Boom single top	× 1
L	2.065m
W	1.16m
H	0.7m
W	0.26t

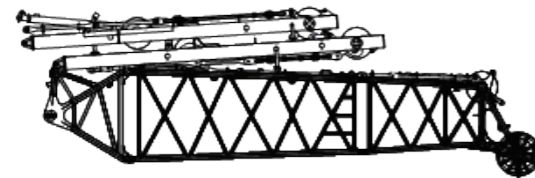

Tower jib quintuplet	× 1
L	10.04m
W	2.18m
H	3.22m
W	6.20t
Include tower jib base, transition section, tower jib top, front strut, rear strut, pendant, backstop device and etc.	

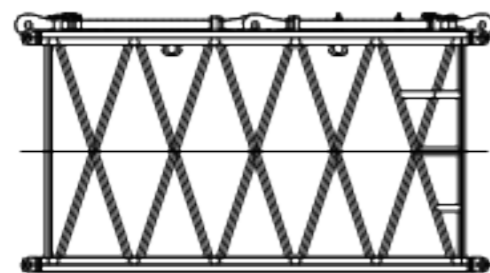

Tower jib 3m insert C	× 1
L	3.17m
W	1.79m
H	1.59m
W	0.5t
Including pendants	

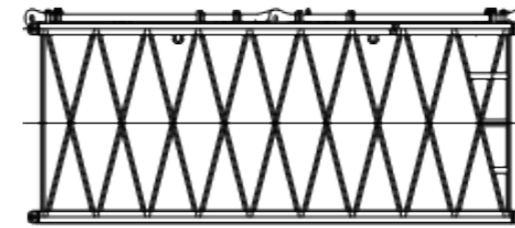

Tower jib 6m insert C	× 1
L	6.17m
W	1.79m
H	1.59m
W	0.8t
Including pendants	

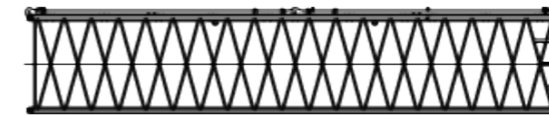

Tower jib 12m insert C	× 2
L	12.17m
W	1.79m
H	1.59m
W	1.50t
Including pendants	

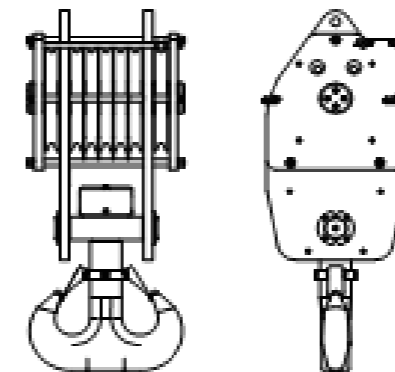

160t hook block assy	× 1
L	0.866m
W	0.76m
H	2.35m
W	2.20t

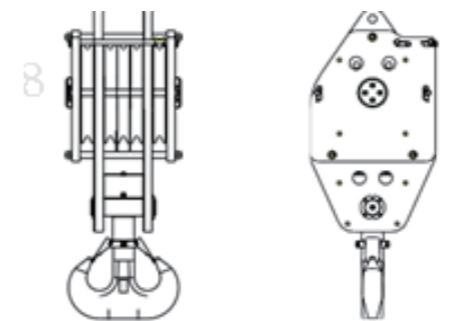

100t hook block assy	× 1
L	0.704m
W	0.76m
H	1.895m
W	1.67t

