

徐工徐工 助您成功
XCMG FOR YOUR SUCCESS



XGC75 履带起重机

CRAWLER CRANE



地址(Add): 中国江苏省徐州市金山桥经济开发区桃山路19号 邮编(Postal Code): 221004
No.19 Taoshan Road, Economic development zone of jinshanqiao,Xuzhou,Jiangsu Province,China
统一服务热线(Unified service hotline): 86 400-110-9999
销售热线Sales Hotline
销售电话(Sale Tel): 86 0516-87892094
销售传真(Sale Fax): 86 0516-87892074
电子邮件(E-mail): jjyxd@xcmg.com
服务质量投诉电话
(Quality Supervision Tel): 86 0516-87892587

服务热线Service Hotline
服务电话(Service Tel): 86 400-001-5678
服务传真(Service Fax): 86 0516-87892080
备件电话(Service Tel): 86 0516-87892086
备件传真(Service Fax): 86 0516-87892083



欢迎访问徐工商城
省心更省钱一站式



欢迎关注徐工履带起重机官方微信
1. 直接扫码“XCMG_xgj”添加好友。
2. 查找公众账号“徐工履带起重机”
3. 直接扫描上方二维码



CONTENTS 目录

P02	<ul style="list-style-type: none">◆ 产品亮点 Product Highlights◆ 主要技术参数 The Main Technical Parameters◆ 详细介绍 Brief Introduction
P11	<ul style="list-style-type: none">◆ 工况示意图 Working Mode Illustration◆ 主臂工况臂节组合 Boom Combinations◆ 主臂工作范围 Boom Working Area◆ 主臂起重性能表 Boom Lifting Load Chart◆ 臂端单滑轮起重性能表 Boom Single Pulley Lifting Load Chart
P18	<ul style="list-style-type: none">◆ 固定副臂臂节组合 Fixed Jib Combinations◆ 固定副臂作业范围图 Fixed Jib Working Area◆ 固定副臂起重性能表 Fixed Jib Lifting Load Chart◆ 主要零部件 Main Parts◆ 工作条件及注意 Working Conditions And Cautions

02

XGC75履带起重机 XGC75 CRAWLER CRANE

P03-P03	产品亮点 Product Highlights
P04-P04	主要技术参数 The Main Technical Parameters
P05-P10	详细介绍 Brief Introduction

产品亮点
Product Highlights

01 运输、拆装优化设计

Optimized design of transport and assembly/disassembly

- 主机采用一体化运输设计，无需拆解履带梁和底节臂，大大节省运输成本，提高拆装效率。
Basic machine is an integrated transport design, without disassembling track frame and boom base, greatly save transport costs and improve the assembly/disassembly efficiency.
- 独创人字架自扳起技术，无需油缸，可实现自扳起，实现快速组装。
Unique A-frame gantry self-erection technology, no need of cylinder can achieve self-erection, to realize crane quick assembly.
- 平衡重单件重量不超过4t，小型辅助起重设备即可完成平衡重组装。
Single counterweight weighing no more than 4t, small auxiliary lifting equipment can achieve complete counterweight assembly.

02 液压系统优化设计

Optimized hydraulic system design

- 采用集成设计，减少故障点，同时预留开阔的拆装、维修空间。
Integrated design to reduce failure points, while reserve open space for assembly/ disassembly and maintenance.
- 采用高集成度LUDV主阀，具备多复合操作、合流控制、高低速选择功能，效率保证。
Use of highly integrated LUDV main valve, with the functions of multi-complex operation, control of combined flow, high/low speed selection, to ensure operation efficiency.
- 可选装行业独有的独立旁路过滤、强力磁性吸附装置，强化液压系统过滤、抗乳化能力。
Optional unique independent bypass filtration in the industry, strong magnetic adsorption device, strengthened hydraulic system filtration, and anti-emulsifying ability.

03 通用化、模块化设计

Universal and modular design

- 同平台产品固定副臂、臂端单滑轮、两侧平衡重、吊钩、变幅机构、液压泵及主要阀块均能实现通用、互换，大大降低购买、运输及维修成本。
Common platform products with fixed jib, single top, both-sided counterweight hook block, luffing mechanism, hydraulic pump and main valve block can achieve universal and interchangeable use, greatly reduce purchase, transport and maintenance costs.

04 主、副钩一键切换功能

Main / auxiliary hook one-key-switch-over function

- 可通过一个开关轻松实现主副钩工况的切换，应用范围更广。
One-key-switch is used to easily achieve main/auxiliary hook switch-over, for wider range of applications.

主要技术参数

The Main Technical Parameters

项目(Item)		单位(Unit)	数值(Value)
最大额定起重量 Max. rated lifting capacity	主臂工况 Boom working condition	t	75
	臂端单滑轮工况 Boom single pulley working condition	t	6.5
	固定副臂工况 (不带主钩) Fixed jib working condition (without main hook block)	t	12
	固定副臂工况 (带主钩) Fixed jib working condition (with main hook block)	t	11.3
最大起重力矩 Max. load moment		t · m	286
主臂长度 Boom length		m	13 ~ 58
主臂变幅角度 Boom luffing angle		°	-3 ~ 80
固定副臂长度 Fixed jib length		m	7 ~ 19
主臂与固定副臂夹角 Angle between boom and fixed jib		°	10、30
起升机构最大单绳速度 Hoist winch max. single line speed		m/min	128
主臂变幅机构最大单绳速度 Boom luffing winch max. single line speed		m/min	70
最大回转速度 Max. slewing speed		rpm	2.4
最高行驶速度 Max. travelling speed		km/h	1.2
整机质量(基于13m基本臂,75t起重钩) Total vehicle mass (75t hook block, 13m boom)		t	61
平均接地比压 Mean ground pressure		MPa	0.08
爬坡度 Grade-ability		-	30%
运输状态单件最大质量 Max. mass of single unit in transport state		t	37 (可拆解至22t)
运输状态单件(转台)最大尺寸(长×宽×高) Max. dimension of single unit in transport state (L×W×H)		m	12.7×3.4×3.4



A向 (拆去主起重臂、人字架、变幅滑轮组等)
A direction (main lifting boom, A-frame and luffing pulley block are removed away)

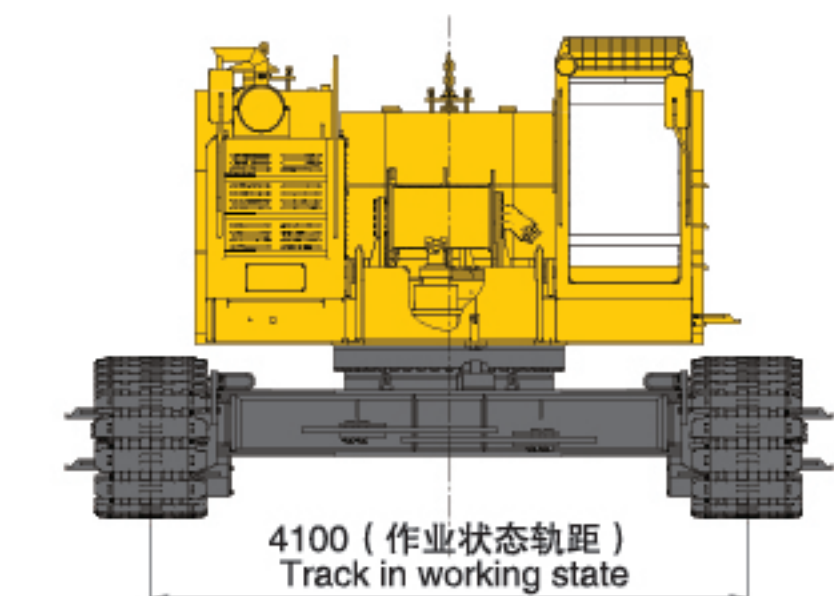

详细介绍 Brief Introduction

上车 / Crane Superstructure

发动机系统/Engine System

①型号：上柴SC7H210.1G3
 额定功率/转速：155kW/2000rpm
 最大扭矩/最大扭矩转速：930N·m/1300-1600rpm
 环保性：符合国Ⅲ标准；
 ②另可选装康明斯QSB6.7发动机；
 额定功率：153kW/1800rpm；
 最大扭矩/最大扭矩转速：931N·m/1300rpm；
 环保性：符合欧Ⅲ（StageⅢA）标准；
 燃料箱容量：400L。

①Model: Shanghai diesel SC7H210.1G3.
 Rated power: 155kW/2000rpm
 Max. torque/Max. torque speed: 930N·m/1300-1600rpm
 Environmental protection: China GB Ⅲ standard;
 ②Optional model: Cummins QSB6.7;
 Rated output power: 153kW/1800rpm;
 Maximum torque / maximum torque. Speed: 931N·m/1300rpm;
 Environmental protection: complaint with Euro III (Stage IIIA)
 emission standard;
 Fuel tank capacity: 400L.

液压系统/Hydraulic System

采用液压先导比例控制的负载敏感LUDV系统，可实现与负载无关的流量分配，速度精准，操作灵敏，系统稳定、微动性好。专用LUDV集成式主阀，可实现任意动作的复合操作，结构紧凑，检修方便。创新性采用微控调节技术，大大提高整车动作的平稳性与精确度。
 主起升、副起升具有双泵合流功能，轻松实现卷扬高低速控制。专用回转缓冲油路设计，回转启停平稳、柔和，满足精细吊装作业要求。
 液压油箱容积：400L。

Use of LUDV load sensing system controlled by hydraulic pilot proportional control, can achieve flow distribution independent of load, with accurate speed, sensitive operation, system stability, good fine motion. Specialized LUDV integrated main valve can achieve combined operation of any movement, compact structure, and easy maintenance. Innovative use of fine motion control technology greatly improves the stability and precision for the whole machine movements.
 Main hoist and auxiliary hoist winches have double pump confluence, easy to achieve winch high/low speed control. Specialized slewing buffer circuit design, slewing start and stop is smooth and soft, to meet the requirements of fine lifting operation.
 Hydraulic tank capacity: 400L.

电气系统/Electrical System

电气系统主要包括如下部分：发动机控制、监测仪表、辅助设备、液压系统控制、力矩限制及安全监控等。
 电气系统的构成：常规电气系统和PLC监控系统。
 常规电气系统采用24V并联回路，用电设备接线采用负极搭铁的线制。包括电源、启动控制、驾驶室冷暖空调及音响、照明(灯光)、雨刮器等。
 PLC监控系统包括主副卷扬、回转、主臂变幅等动作的控制、发动机状态监测。所有动作全部采用液比例控制技术，通过CAN-bus总线技术的PLC逻辑控制，能有效保证主机各功能的实现，充分体现以人为本的设计思想。

Electrical system mainly includes the following components: engine control, monitor instruments, auxiliary equipment, hydraulic system control, load moment limiter, and safety monitors.
 Electrical system composition: conventional electrical system and PLC control system.
 Conventional electrical system uses 24V parallel circuit, electric equipment wiring uses negative ground single-line system, including power supply, start control, cab air conditioner and sound, lights (lamps), wiper and so on.
 PLC control system includes control of main and auxiliary winches, slewing, boom luffing and other movements, engine condition monitoring. All the movements are used with hydraulic proportional control technology, through PLC logic control of CAN-bus technology, effectively ensure the realization of main machine functions, and fully reflects the people-oriented design.

操纵室/Operator's Cab

操纵室造型采用仿生设计的手法，线条流畅又不失力量感。操纵室玻璃面积更大，侧面的玻璃划分更合理，科技感更强，操纵视野更宽阔。内饰以人为中心进行布置，操作者不用起身即可触碰到所有按键。配置可调式座椅、冷暖空调、电源插座、收音机等，为操作者提供了舒适的操作环境。

Operator's cab is designed in bionic modeling, with smooth lines without losing the sense of power. Cab has a larger glass area, side glass has more reasonable partition, more technological sense, and wider field of vision. Interior decoration is arranged as human-centered lay-out, the driver can touch all the switches and buttons without getting up, equipped with adjustable seats, air conditioner, power supply socket, radio, etc., provides the operator with a comfortable operation environment.

转台/Turntable

转台是联系上下车的关键承载结构件，主受力结构采用高强度钢板焊接而成的平板式箱型结构，两侧通过焊接悬臂结构增加整机空间，用于布置固定载荷。转台通过回转支承与下车进行联接。主臂底节、人字架、起升机构、变幅机构和平衡重布置在主受力结构上；操纵室、发动机系统、主泵、液压阀、电控柜等结构布置在两侧悬臂结构上，转台主体结构 and 两侧悬臂结构根据整机的受力状况设计，结构合理，整体强度和刚度好。

Turntable is the key load bearing structure to connect superstructure and undercarriage, the main force structure is welded with steel plate in flat box-type structure, increase the overall space by welded cantilever structure on both sides for arranging the fixed load. Turntable is connected with undercarriage by slewing ring. Boom base, gantry, hoist winch, luffing winch and counterweight are arranged on the main force structure; cab, engine system, main pump, hydraulic valve, electric cabinet and other structures arranged on cantilever structure on both sides; turntable main structure and cantilever structure of both sides are design according to the overall force condition, with reasonable structure, good overall strength and stiffness.

变幅机构/Luffing Winch

变幅机构内置行星减速机，采用湿式叠片式常闭制动器，实现“弹簧制动/液压释放”功能。
 主变幅卷筒采用球墨铸铁制造的双折线多层卷绕单联卷筒，具有良好的吸振性，可保证钢丝绳多层卷绕不乱绳，有效地延长了钢丝绳的使用寿命。卷筒设有棘轮锁止装置，由液压油缸驱动棘爪，实现多重锁定保护。
 变幅机构采用独立钢芯、高破断拉力、结构稳定性极佳的左旋交互捻非抗旋转特种钢丝绳。

变幅机构 Luffing gear	额定单绳拉力 Rated single line pull	6.3t
	钢丝绳直径φ Wire rope diameter	20mm
	长度 Length	135m

Luffing winch has built-in planetary reducer, use of negative brake design, multi-plate wet type laminated constant closed brake, to achieve "spring brake/ hydraulic release" function.
 Main luffing winch drum is made of nodular cast iron with bi-fold cord multi-winding single drum for good vibration absorption, ensure no twisting of multi-winding rope, effectively prolong the rope service life. The drum has a ratchet locking device, pawl driven by a hydraulic cylinder, to achieve multiple lock protection. Luffing winch uses left-turning same-twisting anti-rotation special rope with independent steel core, high breaking force and high anti-extrusion, rated single line pull 6.3t, rope diameter φ 20 mm, length 135m.

回转机构/Slewing Unit

回转机构与回转支承采用内啮合方式驱动，布置在转台前部，由定量马达驱动行星齿轮减速机通过小齿轮驱动回转支承，实现360°回转。
 回转机构内置行星减速机，采用负制动设计的多片湿式叠片式常闭制动器，以实现“弹簧制动/液压释放”功能，确保回转具有极高的制动安全性。回转机构还设有机械式回转锁定装置，以实现回转机构的锁定保护。
 偏心机构可保证减速机和回转支承更好啮合，使回转更平稳。回转机构具有自由滑转功能，保证起重物起吊时，当起重吊钩即使不在被吊重物的重心垂直中心线上，也可以消除臂架的侧向力，进而防止作业臂因受到较大侧向力而损坏。

Slewing unit with slewing ring is internally engaged drive type, arranged in front of the turntable, driven by constant displacement motor via a planetary gear reducer through pinion to drive slewing ring, to achieve 360° slewing.
 Slewing unit has built-in planetary reducer, use of negative brake design, multi-plate wet type laminated constant closed brake, to achieve "spring brake/ hydraulic release" function, to ensure slewing with high braking safety. Slewing unit also has a mechanical slewing locking device to achieve locking protection for the slewing unit.

Eccentric mechanism can ensure better engagement between reducer and slewing ring for more stable slewing. Slewing unit has free-swing function to ensure that the lateral force on boom can be eliminated even when the hook block is not on the vertical line of center of gravity of the load in lifting operation, and furthermore to preventing the boom from damage due to large lateral force.

人字架/Gantry

人字架由双肢结构组成，两肢之间有加强横梁，稳定性好。人字架主要结构为优质无缝钢管，有效减少焊接量，制造缺陷少，安全系数高。人字架上配备自扳起托辊，可在主臂底节臂的配合下实现自扳起功能。

Gantry is double-limb structure, with reinforced beam between the two limbs for good stability. Gantry main structure is high-quality seamless steel pipe, with less welding, little manufacturing defects, and high safety factor. Gantry is equipped with self-erection roller, can achieve self-erection function in coordination with boom base.

详细介绍 Brief Introduction

起升机构/Hoist Winch

主起升、副起升机构内置行星减速机，采用负制动设计多片湿式叠片式常闭制动器，实现“弹簧制动/液压释放”功能，安全可靠。采用溅油方式润滑，减少维护保养强度。起升机构还具有换油方便、低噪音、高效率、长寿命等特性，同时具有优良的微速性能。起升卷筒采用吸振性良好的球墨铸铁制造，双折线绳槽保证钢丝绳多层卷绕不乱绳，有效地延长了钢丝绳的使用寿命。主起升机构使用独立钢芯、高破断拉力、高抗挤压性的左旋同向捻抗旋转特种钢丝绳。

主起升机构 Main hoist gear	额定单绳拉力 Rated single line pull	6.6t
	钢丝绳直径φ Wire rope diameter	20mm
	长度 Length	240m
副起升机构 Auxiliary hoist gear	额定单绳拉力 Rated single line pull	6.6t
	钢丝绳直径φ Wire rope diameter	20mm
	长度 Length	140m

Main hoist winch and auxiliary hoist winch has built-in planetary reducer, use of negative brake design, multi-plate wet type laminated constant closed brake, to achieve "spring brake / hydraulic release" function, safe and reliable. Hoist winch also has the features of easy oil replacing, low noise, high efficiency, and long service life. It also has excellent micro-speed performance. Hoist winch drum is made of nodular cast iron with good vibration absorption, bi-fold cord rope grooves ensure no twisting of multi-winding rope, effectively prolong the rope service life. Main hoist winch uses left-turning same-twisting anti-rotation special rope with independent steel core, high breaking force and high anti-extrusion, rated single line pull 6.6t, rope diameter φ 20 mm, length 240m. Auxiliary hoist winch also uses left-turning same-twisting anti-rotation special rope with independent steel core, high breaking force and high anti-extrusion, rated single line pull 6.6t, rope diameter φ 20 mm, length 140m.

平衡重/Counterweight

平衡重共21.6t，安装在转台后方，与转台采用销轴挂靠式连接。平衡重组成如下：
平衡重托盘1×4t，左右平衡重块6×2t，中央平衡重块2×2.8t。

Counterweight is total 21.6t, installed at the rear of turntable, anchored connection by pin shaft, counterweight composition is as the follows:
Counterweight tray 1×4t, left/right counterweight slab 6×2t, central counterweight slab 2×2.8t.

下车 / Crane Undercarriage

下车包括车架、履带行走装置等。车架和履带行走装置之间采用插入式连接。

Crane undercarriage consists of car-body, crawler travel unit and etc. The inserting type connection is used between car-body and crawler travel unit.

履带行走装置/Crawler Travel Unit

履带行走装置由履带架、履带板、支重轮、驱动轮、导向轮、托链轮及行走机构、张紧装置组成。
履带架：左右对称，各1件。采用高强度钢板焊接成的箱型结构，与车架采用插入式连接方式，抽屉式上下间隙调整装置，确保履带架安装后不会产生横向的八字现象，避免履带板与支重轮产生偏磨。
履带板：高强度耐磨合金钢铸件，宽度760mm，共2×63=126件。
行走机构：常闭式行星齿轮减速机，采用斜轴柱塞马达驱动。行走动力强劲，可实现直线行走、原地转向、单边转向、差速转向及带载行走等动作，有极高的灵活性和机动性。多片湿式常闭制动器，弹簧制动，液压松闸，确保行走具有高的制动安全性。
最高行走速度：1.2km/h。

Crawler travel travel unit, consists of track frame, track shoe, track roller, sprocket, idle roller, carrier roller, crawler travel unit, and crawler tensioning device.

Track frame: left/right symmetrical, each of one piece, steel plate welded into box-type structure, inserting type connection with car-body, drawer type device to adjust upper and lower space, to ensure no lateral horoscope phenomenon on track frame after installation, avoid eccentric wear between track shoe and track roller.

Track shoe: high strength wear-resistant alloy steel casting, width 760mm, total 2×63 =126 pieces.

Travel unit: constant closed planetary reducer, driven by oblique axis piston motor, with powerful travel, can achieve straight-line walk, steering at a position, single one side steering, differential steering and travel with a load and other movements, for high flexibility and mobility, with multi-plate wet type constant closed brake, spring brake, hydraulic release valve, to ensure travel with high braking safety.

Maximum travel speed: 1.2km/h.

车架/Car-Body

车架为H型箱型结构，采用高强度钢板焊接而成，整体刚性好、强度大、精度高。上平面经精密机加，确保回转支承的正确安装。

Car-body is H box-type structure welded with high-strength steel plate, with good rigidity, high strength, high precision. Upper plane is by precision machining, to ensure smooth operation of slewing ring.

安全装置/Safety Devices

本起重机广泛采用机械、电子和液压等多种安全及报警装置，以确保机器的安全使用。安全装置包括力矩限制器、回转锁定装置、起重臂防后翻装置、起升高度限位装置、起重臂角度限位装置、风速仪、水平仪、回转警告及液压系统溢流阀、平衡阀、液压锁等。

This crane widely uses mechanical, electronic and hydraulic and other safety and warning devices to ensure the safe use of the machine. The safety devices include: load moment limiter, slewing lock device, boom backstop device, hoist limit switch, boom angle limiter, anemometer, electronic level meter, slewing warning and hydraulic system relief valve, balance valve, hydraulic lock, and etc.

安装模式&工作模式切换开关

Assembly Mode & Work Mode Exchange Switch

安装模式下，防过卷装置、起重臂限位装置、力矩限制器等均不起作用，以利于起重机安装；工作模式下，所有安全装置均起作用。

In Assembly mode, over-wound protection device, boom backstop device, load moment limiter does not work, in order to facilitate crane assembly. In Work mode, all safety devices do work.

防过卷装置/Winch Over-Wound Protection Device

臂头设置主起升和副起升过卷装置，防止钢丝绳过卷。当主卷扬、副卷扬起升到一定高度时候，显示器上的过卷指示灯亮，同时力矩限制器停止起升动作。

When main/auxiliary winch hoists up to a certain lifting height, a winch over-wound warning lamp on instrument panel lights up, at the same time, load moment limiter stops crane hoisting up movements.

紧急停止按钮/Emergency Stop Switch

紧急情况下，按下此按钮将停止所有动作。

In emergency conditions, press this button to stop all the crane movements.

详细介绍 Brief Introduction

防过放保护/Winch Over-Release Protection Device

主起升、副起升机构均设置三圈保护器，避免卷筒放绳时产生过放。当主卷扬、副卷扬钢丝绳只剩三圈时，显示器上的过放指示灯亮，同时力矩限制器停止下落动作。

A rope-end limiter is set on main and auxiliary hoist winch to prevent wire rope from over-release. When only three turns of main and auxiliary winch rope is remained on the winch drum, a winch over-release warning lamp on instrument panel lights up, at the same time, load moment limiter stops crane hoisting down movements.

棘爪锁止装置/Ratchet Locking Device

该功能用于锁定主变幅卷扬，用于保护臂架在非工作安全停放。

It is used to lock the luffing winch drum to protect boom stowing safety at non-working state. It must be turned on when lowering boom, otherwise boom cannot be lowered.

机械式安全装置/Mechanical Safety Device

回转锁止装置用于起重机停止时上车的机械限位；主臂、副臂支架防后翻装置，防止臂架及支架的后仰。

Slewing locking device is used for the mechanical limit stop when stopping the crane; it consists of boom/ jib strut backstop device to prevent the boom and strut tipping backward.

起重臂角度限制/Boom Angle Limit

主臂架起到规定角度时，起升被停止，由力矩限制器和行程开关双级控制；主臂架在仰角小于规定角度时，下落被停止，由力矩限制器控制并发出声音报警。

When boom is raised to the specified angle, the boom raising is stopped by both control of load moment limiter and hoist limit switch. When boom luffing angle is less than the specified angle, boom lowering is stopped by control of load moment limiter and which also gives a sound warning.

起重钩防脱卡/Hook Latch

所有起重钩均装有防脱卡板，防止悬挂在起重钩头的吊索脱落。

All hook blocks are equipped with hook latch to prevent the hanging rope on the hook head from falling.

液压系统/Hydraulic System

配置液压平衡阀、液压溢流阀等装置，保证系统工作时稳定安全。

Hydraulic system is equipped with hydraulic balance valve, hydraulic relief valve and other devices to ensure the stable and safe work for the system.

风速仪 /Anemometer

实时检测当前风速，并传送到操纵室的监视器上，提醒操作者注意风载荷安全。

It can detect the current wind speed and send signal to the monitor in operator's cab to remind the operator for safe operation in wind load.

后视镜/Rearview Mirror

照明灯装在转台前方、操纵室上方和操纵室内，用于夜间工作提供照明起重机向危险的方向运行。

It is located outside the operator's cab for the driver easy to observe the situation behind the machine.

示高灯/Height Mark Lamp

示高灯安装在臂架顶部，作为高空警示。

It is located on boom tip for high level operation warning

力矩限制器系统/Hydraulic System

检测功能：力矩限制器能自动检测出起重臂的角度、起重载荷。

显示功能：彩色大屏7.0寸液晶显示器。用中文(或英文)和图形方式显示力矩百分比、实际起重量、额定起重量、工作半径、吊臂长度、角度、最大起升高度、工况代码、倍率、限制角度、信息代码等起重作业参数。

警示功能：具有完整的预先报警、超载停止作业功能。如果检测到实际载荷超过额定载荷，起重臂超过极限角度，力矩限制器发出报警并限制当前动作。系统具有故障自诊断功能。

Detection function: automatic detection of boom angle and lifting load.

Display function: 7.0" large color screen display to indicate in Chinese (English) and graphics the crane working parameters such as the percentage of load moment, actual lifting capacity, rated lifting capacity, working radius, boom length, boom angle, max. lifting height, mode code, parts of line, limit angle and information code.

Warning function: perfect pre-warning and overload cut-out functions, automatically send out warning signal and stop crane operation when detecting actual lifting load exceeding total rated lifting load and boom out of limit angle.

The system also has the fault self-diagnosis function.

三色力矩报警灯 /Tricolor Warning Lamp

三色力矩报警灯由三种颜色组成，力矩百分比在90%以下时“绿灯”亮，表示起重机在安全区域运行；力矩百分比在90%~100%时“黄灯”亮，表示起重机在已接近额定载荷范围。力矩百分比高于100%时，“红灯”亮，表示起重机已经超载，在危险区域，控制系统自动切断起重机向危险的方向运行。

The lamp comprises 3 colors, when the percentage of load moment is below 90%, "Green Lamp" lights on to indicate that the crane is running in safety; when the percentage of load moment is in 90%~100%, "Yellow Lamp" lights on to indicate that the crane is close to total rated lifting load; when the percentage of load moment is above 100%, "Red Lamp" lights on to indicate that the crane is in overload and in dangerous area, at this time the control system can automatically cut off crane movement to dangerous direction.

照明灯/Illumination Lamp

照明灯装在转台前方、操纵室上方和操纵室内，用于夜间工作提供照明起重机向危险的方向运行。

The illuminator lamp is in front of turntable, on the top of and inside operator's cab for lighting in night operation.

声光报警器 /Audio/Video Alarm

在履带起重机做回转动作时，声光报警器灯可闪烁和发出声音进行报警。

When crawler crane is slewing, the audio/video warning lamps flash and give sound for warning.

11

XGC75履带起重机 XGC75 CRAWLER CRANE

- P12-P13 工况示意图
Working Mode Illustration
- P14-P14 主臂工况臂节组合
Boom Combinations
- P15-P15 主臂工作范围
Boom Working Area
- P16-P16 主臂起重性能表
Boom Lifting Load Chart
- P17-P17 臂端单滑轮起重性能表
Boom Single Pulley Lifting Load Chart

工况示意图 Working Mode Illustration

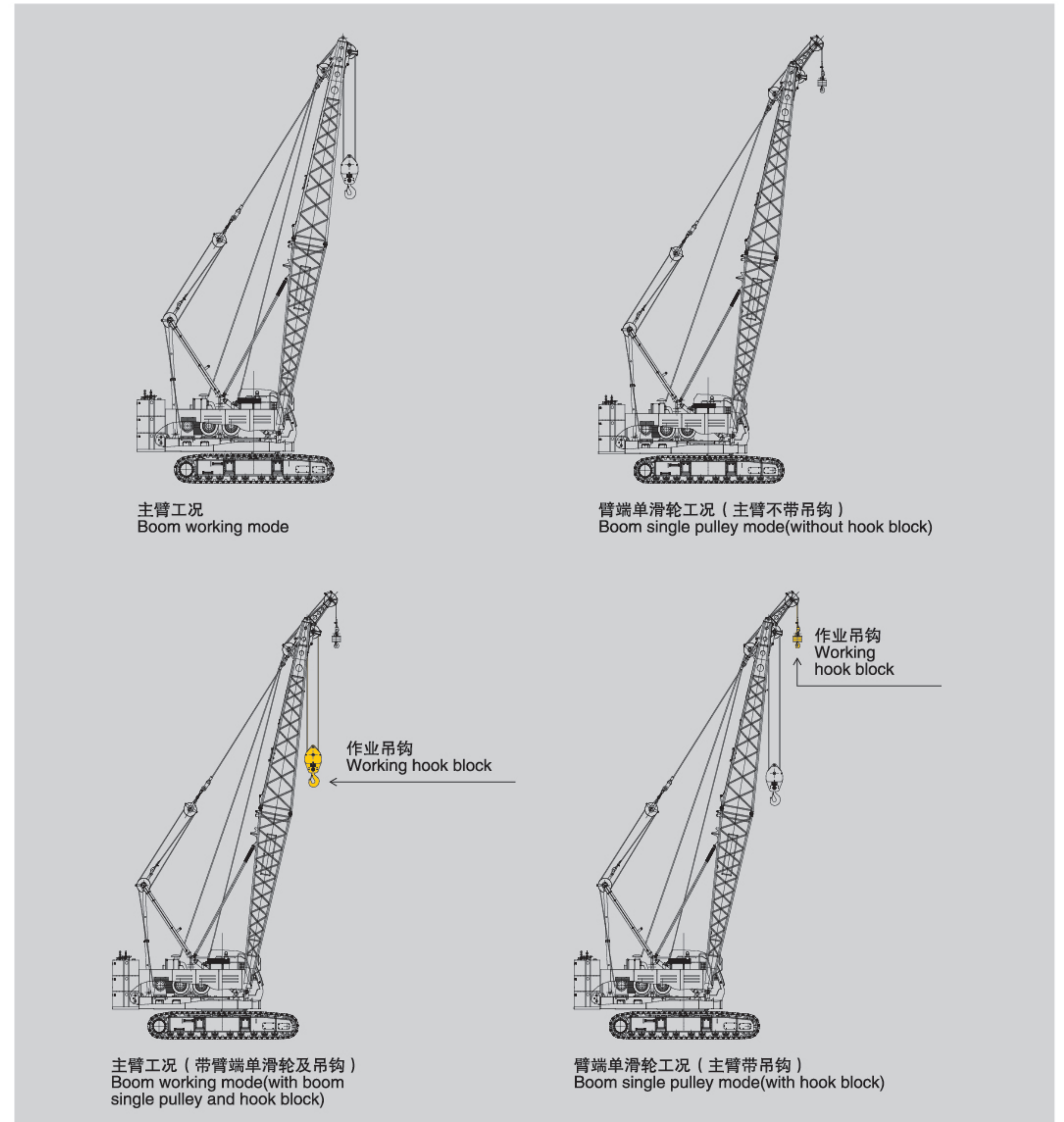

工况示意图
Working Mode Illustration

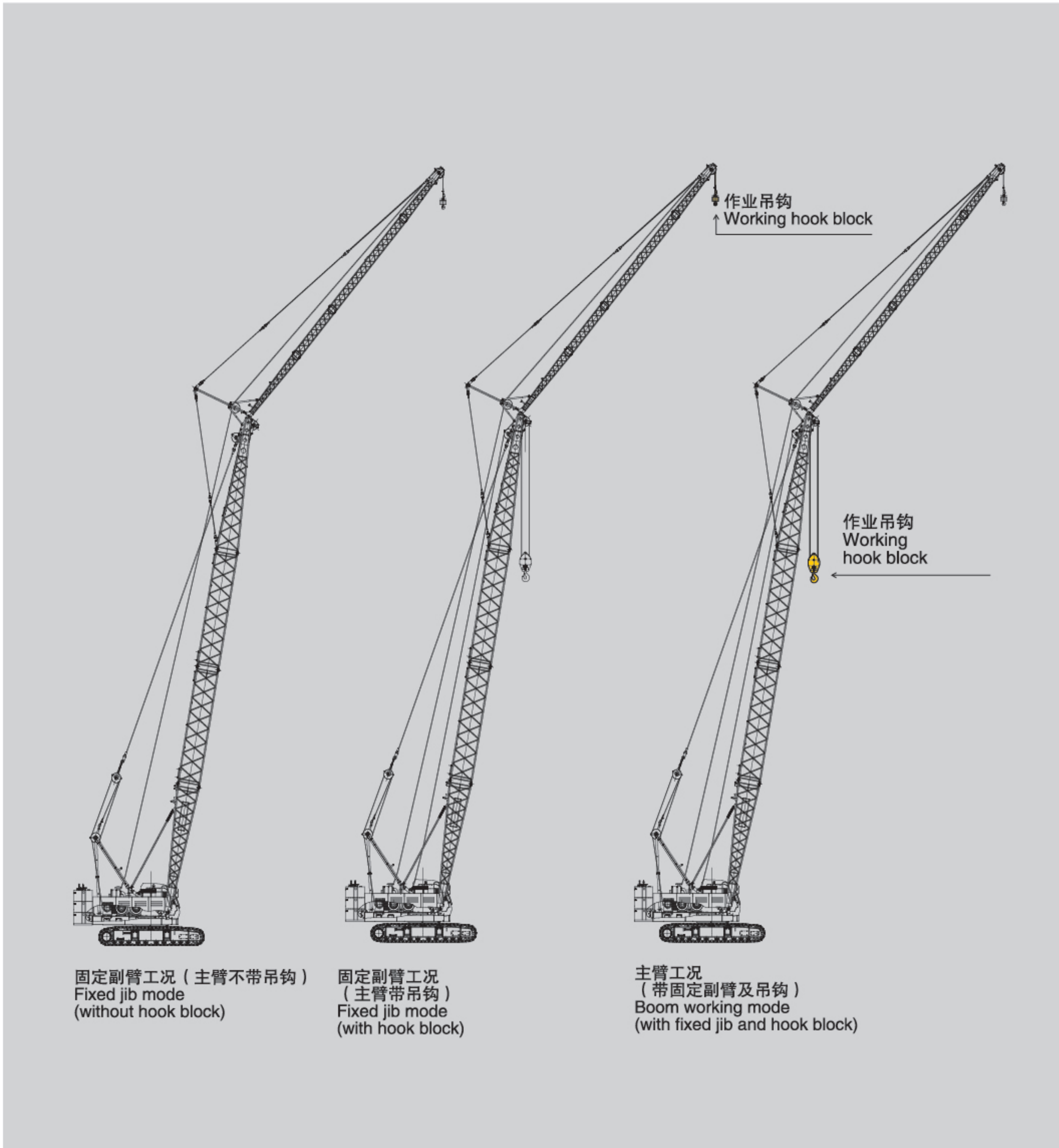

主臂工况臂节组合
Boom Combinations

主臂长度 (m)	底节臂 6.5m	中间臂节			顶节臂 6.5m
		3m	6m	9m	
13	1	-	-	-	1
16	1	1	-	-	1
19	1	-	1	-	1
22	1	-	-	1	1
	1	1	1	-	1
25	1	1	-	1	1
28	1	-	1	1	1
31	1	-	-	2	1
	1	1	1	1	1
34	1	1	-	2	1
37	1	-	1	2	1
40	1	-	-	3	1
	1	1	1	2	1
43	1	1	-	3	1
46	1	-	1	3	1
49	1	-	-	4	1
	1	1	1	3	1
52	1	1	-	4	1
55	1	-	1	4	1
58	1	1	1	4	1

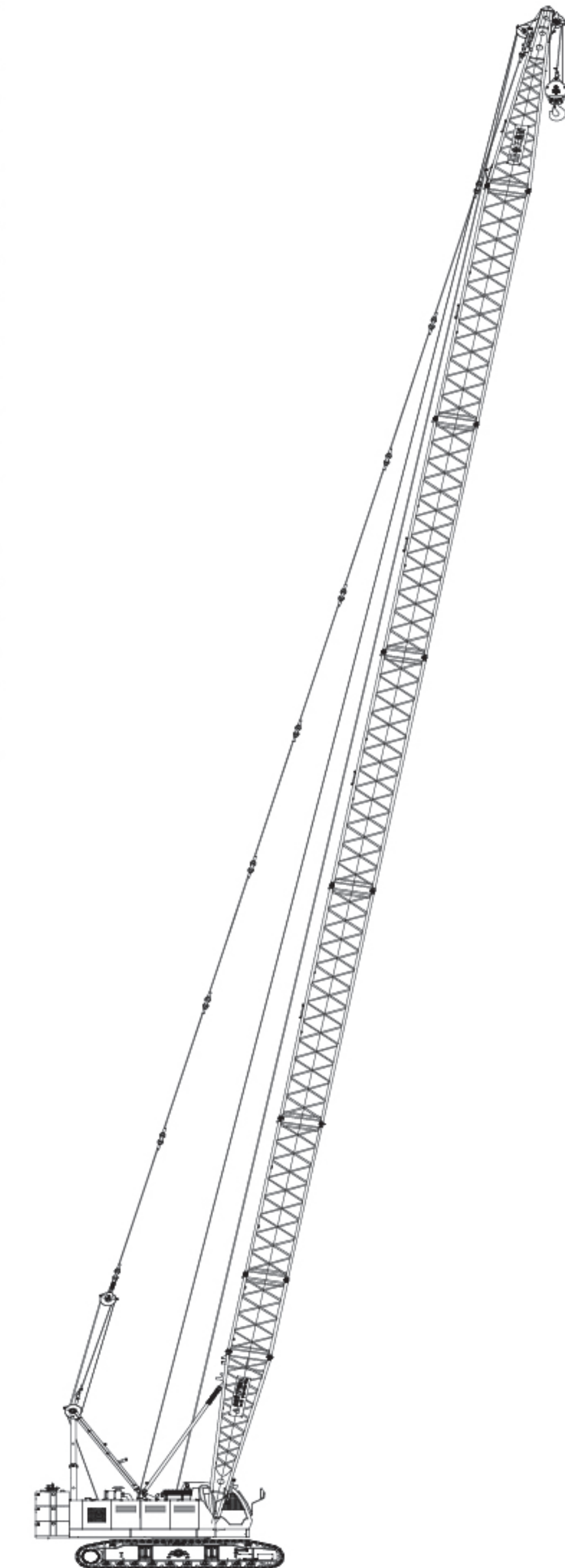

主臂工作范围
Boom Working Area

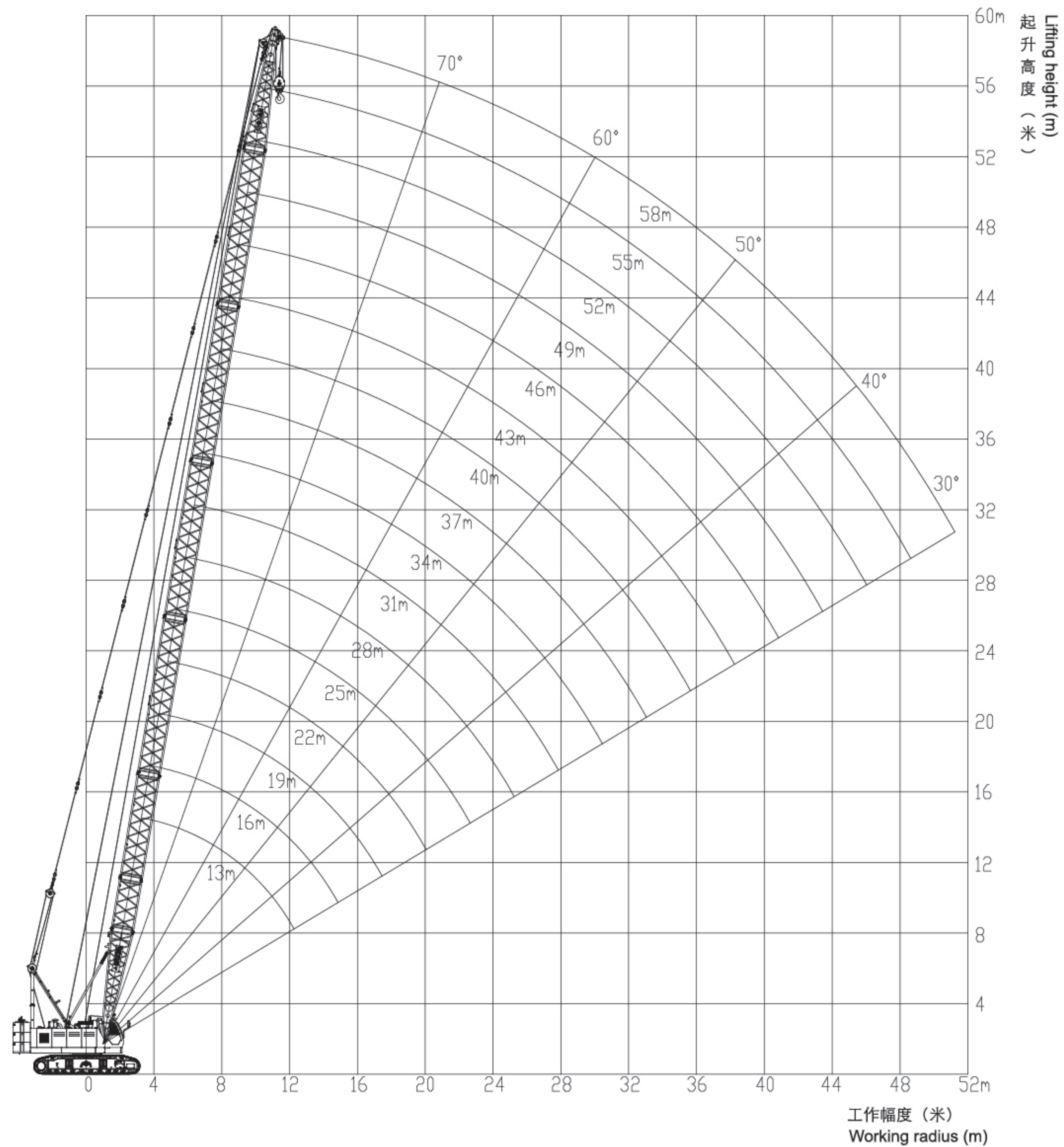

主臂起重性能表
Boom Lifting Load Chart

幅度 Radius (m)	主臂长度 Boom length (m)								幅度 Radius (m)
	13	16	19	22	25	28	31	34	
3.6	75								3.6
4	71.5	68.0/4.2							4
5	56.5	55.5	55	47.5/5.3					5
6	43.5	42.7	41.9	41.5	40.9	35.2/6.5			6
7	34.5	34.3	34.2	33.7	32.7	32.1	31.7	28.2/7.5	7
8	28.5	28.4	28.4	28.3	27.9	27.3	26.8	26.3	8
9	24.2	24.0	23.9	23.8	23.6	23.4	23.2	22.6	9
10	20.9	20.9	20.8	20.7	20.6	20.5	20.1	19.9	10
12	16.4	16.3	16.3	16.2	16.1	16	15.9	15.8	12
14		13.3	13.3	13.2	13.1	13	12.9	12.8	14
16			11.1	11	10.9	10.8	10.7	10.6	16
18				9.4	9.3	9.2	9.1	9	18
20				8.2	8.1	8	7.9	7.8	20
22					7.1	7	6.9	6.8	22
24						6.2	6.1	5.9	24
26							5.4	5.3	26
28								4.7	28
30								4.2	30

幅度 Radius (m)	主臂长度 Boom length (m)								幅度 Radius (m)
	37	40	43	46	49	52	55	58	
8	25.9								8
9	22.0	21.7	21.5						9
10	19.6	19.3	19.2	18.9	18.4	16.5/10.7	14.2/11		10
12	15.6	15.4	15.2	14.8	14.5	13.9	13.5	12.5	12
14	12.7	12.6	12.4	12.2	12.0	11.7	11.4	11.0	14
16	10.5	10.4	10.3	10.2	10.0	9.8	9.6	9.4	16
18	8.9	8.8	8.7	8.5	8.4	8.3	8.1	7.9	18
20	7.6	7.5	7.4	7.3	7.2	7	6.9	6.8	20
22	6.6	6.5	6.4	6.3	6.2	6	5.9	5.8	22
24	5.8	5.7	5.6	5.5	5.3	5.2	5.1	4.9	24
26	5.1	5	4.9	4.8	4.6	4.5	4.4	4.2	26
28	4.6	4.4	4.3	4.2	4.1	3.9	3.8	3.7	28
30	4.1	3.9	3.8	3.7	3.6	3.4	3.3	3.2	30
32	3.6	3.5	3.4	3.3	3.1	3	2.9	2.7	32
34		3.1	3	2.9	2.8	2.6	2.5	2.3	34
36			2.7	2.6	2.4	2.3	2.2	2	36
38			2.4	2.3	2.1	2	1.9	1.7	38
40				2	1.9	1.7	1.6	1.4	40
42					1.6	1.5	1.4	1.2	42
44						1.3	1.2	1	44
46						1.1	1		46

臂端单滑轮起重性能表
Boom Single Pulley Lifting Load Chart

工作幅度 Working Radius (m)	主臂长度Boom length (m)															工作幅度 Working Radius (m)				
	13	16	19	22	25	28	31	34	37	40	43	46	49	52	55		58			
5	6.5																5			
6	6.5	6.5															6			
7	6.5	6.5	6.5	6.5													7			
8	6.5	6.5	6.5	6.5	6.5	6.5											8			
9	6.5	6.5	6.5	6.5	6.5	6.5	6.5										9			
10	6.5	6.5	6.5	6.5	6.5	6.5	6.5	6.5	6.5	6.5	6.5						10			
12	6.5	6.5	6.5	6.5	6.5	6.5	6.5	6.5	6.5	6.5	6.5	6.5					12			
14		6.5	6.5	6.5	6.5	6.5	6.5	6.5	6.5	6.5	6.5	6.5	6.5	6.5			14			
16		6.5	6.5	6.5	6.5	6.5	6.5	6.5	6.5	6.5	6.5	6.5	6.5	6.5	6.5		16			
18			6.5	6.5	6.5	6.5	6.5	6.5	6.5	6.5	6.5	6.5	6.5	6.5	6.5	6.5	18			
20				6.5	6.5	6.5	6.5	6.5	6.5	6.5	6.5	6.5	6.5	6.5	6.5	6.5	20			
22				6.5	6.5	6.5	6.5	6.5	6.5	6.5	6.5	6.4	6.5	6.1	6	5.9	22			
24					6.5	6.5	6.1	6	5.9	5.8	5.7	5.5	5.4	5.3	5.2	5.1	24			
26						5.5	5.4	5.3	5.2	5.1	5	4.9	4.7	4.6	4.5	4.4	26			
28							4.9	4.8	4.6	4.5	4.4	4.3	4.2	4	3.9	3.8	28			
30								4.4	4.3	4.1	4	3.9	3.8	3.7	3.6	3.4	3.3	30		
32									3.8	3.7	3.6	3.5	3.4	3.2	3.1	3	2.9	32		
34										3.3	3.2	3.1	3	2.9	2.7	2.6	2.5	34		
36											2.9	2.8	2.7	2.5	2.4	2.3	2.2	36		
38												2.6	2.5	2.4	2.2	2.1	2	1.9	38	
40													2.2	2.1	2	1.9	1.7	1.6	40	
42														1.9	1.7	1.6	1.5	1.4	42	
44															1.5	1.4	1.3	1.2	44	
46																1.3	1.2	1.1	1	46
48																	1			48

18

XGC75履带起重机 XGC75 CRAWLER CRANE

- P19-P19 固定副臂臂节组合
Fixed Jib Combinations
- P20-P20 固定副臂作业范围图
Fixed Jib Working Area
- P21-P25 固定副臂起重性能表
Fixed Jib Lifting Load Chart
- P26-P29 主要零部件
Main Parts
- P30-P30 工作条件及注意
Working Conditions And Cautions

固定副臂臂节组合
Fixed Jib Combinations

副臂长度 (m)	底节臂4m	中间臂节		顶节臂3m
		3m	6m	
7	1	-	-	1
10	1	1	-	1
13	1	-	1	1
16	1	1	1	1
19	1	2	1	1

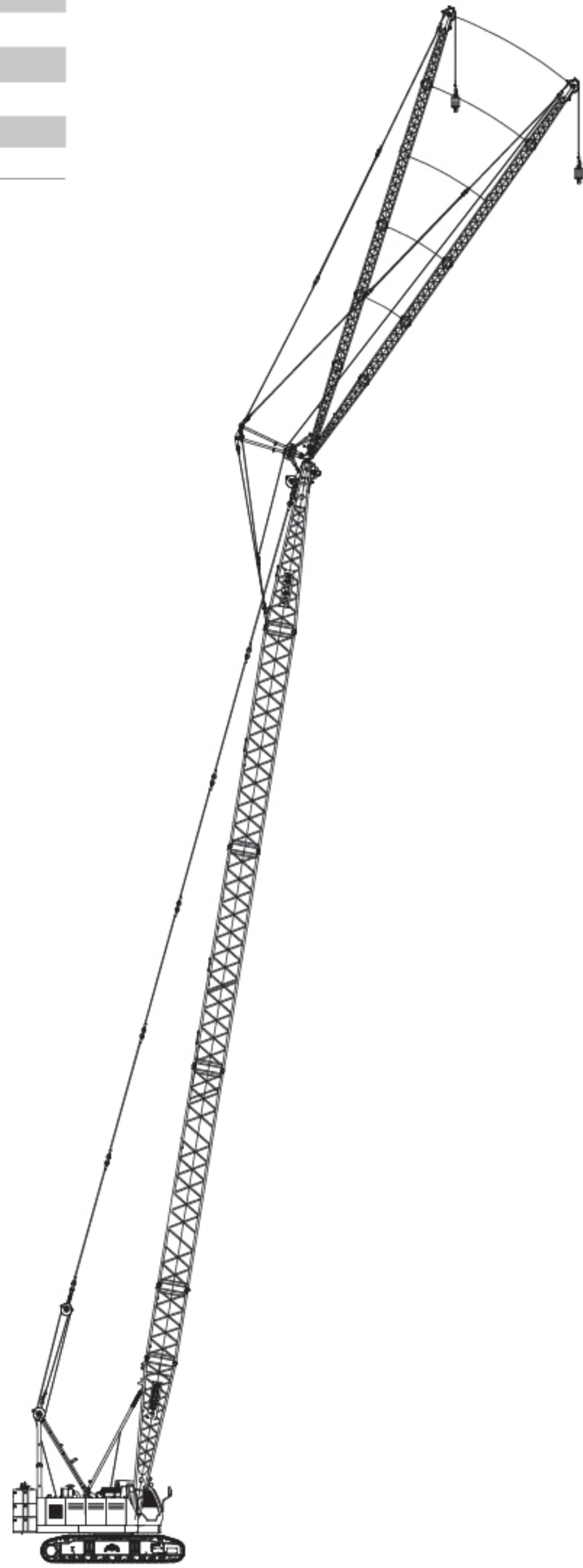

固定副臂作业范围图
Fixed Jib Working Area

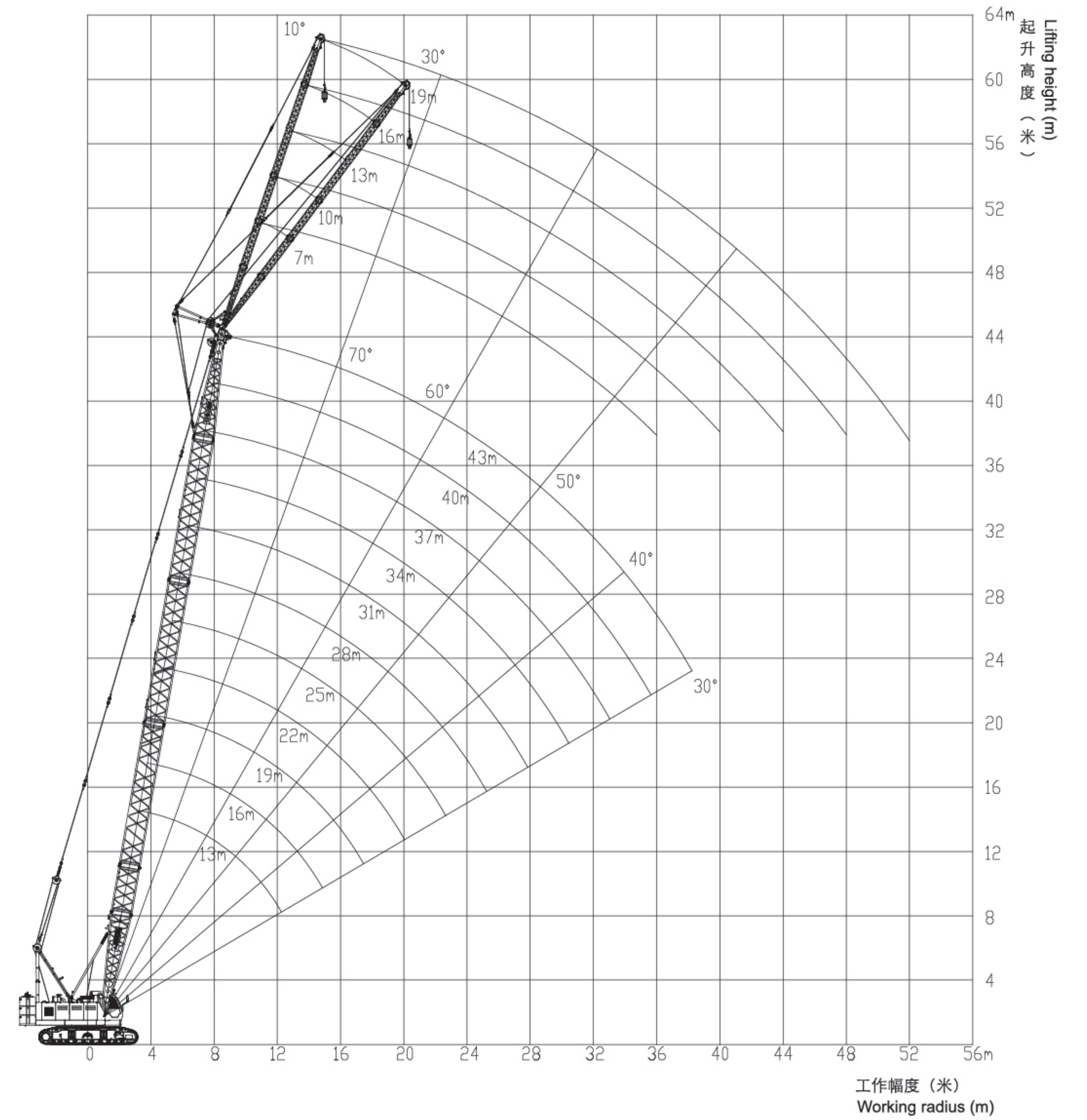

固定副臂起重性能表
Fixed Jib Lifting Load Chart

主臂长 Boom length(m)	28										主臂长 Boom length(m)
固定副臂长 Fixed jib length(m)	7		10		13		16		19		固定副臂长 Fixed jib length(m)
副臂安装角度 Jib angle(°)	10	30	10	30	10	30	10	30	10	30	副臂安装角度 Jib angle(°)
工作幅度 Working radius(m)											工作幅度 Working radius(m)
9	12										9
10	12		9.6								10
12	12	9.9	9.1		7.2		5.6		4.2		12
14	12	9.6	8.6	6.5	6.8		5.3		3.9		14
16	10.7	9.4	8.2	6.3	6.5	4.8	5	3.7	3.7		16
18	9.1	9.2	7.8	6.1	6.1	4.6	4.7	3.5	3.4	2.5	18
20	7.8	8	7.5	5.9	5.9	4.4	4.5	3.4	3.2	2.4	20
22	6.8	6.9	6.9	5.8	5.6	4.3	4.3	3.2	3	2.3	22
24	6	6.1	6.1	5.6	5.3	4.2	4	3.1	2.8	2.2	24
26	5.3	5.4	5.4	5.5	5.1	4.1	3.8	3	2.7	2	26
28	4.8	4.8	4.8	4.9	4.9	4	3.7	2.9	2.5	1.9	28
30	4.3	4.3	4.3	4.4	4.4	3.9	3.5	2.8	2.4	1.8	30
32	3.8	3.8	3.9	3.9	3.9	3.8	3.3	2.7	2.3	1.8	32
34			3.5	3.5	3.6	3.6	3.2	2.6	2.2	1.7	34
36					3.2	3.3	3	2.6	2	1.6	36
38						2.9	2.9	2.5	1.9	1.6	38
40							2.7	2.5	1.8	1.5	40
42									1.7	1.5	42
44										1.5	44

主臂长 Boom length(m)	31										主臂长 Boom length(m)
固定副臂长 Fixed jib length(m)	7		10		13		16		19		固定副臂长 Fixed jib length(m)
副臂安装角度 Jib angle(°)	10	30	10	30	10	30	10	30	10	30	副臂安装角度 Jib angle(°)
工作幅度 Working radius(m)											工作幅度 Working radius(m)
9	12										9
10	12		9.6								10
12	12	9.9	9.2		7.2		5.6				12
14	12	9.7	8.7	6.5	6.9		5.3		4		14
16	10.6	9.5	8.3	6.3	6.6	4.8	5.1		3.7		16
18	9	9.2	8	6.1	6.3	4.6	4.8	3.6	3.5		18
20	7.7	7.9	7.6	6	6	4.5	4.6	3.4	3.3	2.4	20
22	6.7	6.8	6.8	5.8	5.7	4.4	4.4	3.3	3.1	2.3	22
24	5.9	6	6	5.7	5.5	4.2	4.1	3.2	2.9	2.2	24
26	5.2	5.3	5.3	5.4	5.3	4.1	4	3	2.8	2.1	26
28	4.6	4.7	4.7	4.8	4.8	4	3.8	2.9	2.6	2	28
30	4.1	4.2	4.2	4.3	4.3	4	3.6	2.8	2.5	1.9	30
32	3.7	3.7	3.8	3.8	3.8	3.9	3.5	2.7	2.4	1.8	32
34	3.3	3.3	3.4	3.4	3.4	3.5	3.3	2.7	2.3	1.7	34
36			3	3.1	3.1	3.2	3.1	2.6	2.2	1.7	36
38				2.7	2.8	2.8	2.8	2.6	2	1.6	38
40					2.5	2.5	2.5	2.5	1.9	1.6	40
42							2.3	2.4	1.8	1.5	42
44								2.1	1.8	1.5	44
46										1.5	46

固定副臂起重性能表
Fixed Jib Lifting Load Chart

主臂长 Boom length(m)	34										主臂长 Boom length(m)
固定副臂长 Fixed jib length(m)	7		10		13		16		19		固定副臂长 Fixed jib length(m)
副臂安装角度 Jib angle(°)	10	30	10	30	10	30	10	30	10	30	副臂安装角度 Jib angle(°)
工作幅度 Working radius(m)											工作幅度 Working radius(m)
10	12										10
12	12	9.9	9.2		6.5						12
14	12	9.7	8.8	6.5	6.5		5.3		4		14
16	10.4	9.5	8.4	6.3	6.5	4.8	5.1		3.8		16
18	8.9	9.1	8.1	6.2	6.3	4.7	4.9	3.6	3.6		18
20	7.6	7.8	7.7	6	6.1	4.5	4.7	3.5	3.4	2.4	20
22	6.6	6.7	6.7	5.9	5.8	4.4	4.4	3.3	3.2	2.3	22
24	5.8	5.9	5.9	5.8	5.6	4.3	4.2	3.2	3	2.2	24
26	5.1	5.2	5.2	5.3	5.2	4.2	4.1	3.1	2.9	2.2	26
28	4.5	4.6	4.6	4.7	4.6	4.1	3.9	3	2.7	2.1	28
30	4	4.1	4.1	4.2	4.1	4	3.7	2.9	2.6	2	30
32	3.6	3.6	3.6	3.7	3.7	3.8	3.6	2.8	2.5	1.9	32
34	3.2	3.2	3.2	3.3	3.3	3.4	3.3	2.7	2.4	1.8	34
36	2.8	2.8	2.9	3	3	3.1	3	2.7	2.3	1.7	36
38			2.6	2.6	2.7	2.7	2.7	2.6	2.2	1.7	38
40			2.3	2.3	2.4	2.4	2.4	2.5	2.1	1.6	40
42					2.2	2.2	2.2	2.3	2	1.6	42
44							2	2	1.9	1.5	44
46								1.8	1.8	1.5	46
48									1.6	1.5	48

主臂长 Boom length(m)	37										主臂长 Boom length(m)
固定副臂长 Fixed jib length(m)	7		10		13		16		19		固定副臂长 Fixed jib length(m)
副臂安装角度 Jib angle(°)	10	30	10	30	10	30	10	30	10	30	副臂安装角度 Jib angle(°)
工作幅度 Working radius(m)											工作幅度 Working radius(m)
10	12										10
12	12	9.9	6.5		6.5						12
14	12	9.7	6.5	6.5	6.5		5.4		4		14
16	10.2	9.5	6.5	6.3	6.5	4.8	5.1		3.8		16
18	8.7	8.9	6.5	6.2	6.4	4.7	4.9		3.6		18
20	7.5	7.7	6.5	6	6.2	4.5	4.7	3.6	3.4	2.5	20
22	6.5	6.6	6.5	5.9	5.9	4.4	4.5	3.5	3.3	2.4	22
24	5.7	5.8	5.7	5.8	5.7	4.3	4.3	3.4	3.1	2.3	24
26	5	5.1	5	5.2	5.1	4.2	4.2	3.3	2.9	2.2	26
28	4.4	4.5	4.5	4.6	4.5	4.1	4	3.2	2.8	2.1	28
30	3.9	4	4	4.1	4	4.1	3.8	3.1	2.7	2	30
32	3.5	3.5	3.5	3.6	3.6	3.7	3.6	3	2.5	1.9	32
34	3.1	3.1	3.1	3.2	3.2	3.3	3.2	2.9	2.4	1.9	34
36	2.7	2.8	2.8	2.9	2.9	3	2.9	2.8	2.3	1.8	36
38	2.4	2.4	2.5	2.5	2.6	2.6	2.6	2.7	2.2	1.7	38
40		2.1	2.2	2.3	2.3	2.4	2.3	2.7	2.1	1.7	40
42			2	2	2	2.1	2.1	2.4	2.1	1.6	42
44					1.8	1.8	1.8	2.2	1.9	1.6	44
46						1.6	1.6	1.9	1.7	1.5	46
48							1.4	1.7	1.5	1.5	48
50								1.5	1.3	1.4	50
52										1.2	52

固定副臂起重性能表
Fixed Jib Lifting Load Chart

主臂长 Boom length(m)	40										主臂长 Boom length(m)
固定副臂长 Fixed jib length(m)	7		10		13		16		19		固定副臂长 Fixed jib length(m)
副臂安装角度 Jib angle(°)	10	30	10	30	10	30	10	30	10	30	副臂安装角度 Jib angle(°)
工作幅度 Working radius(m)											工作幅度 Working radius(m)
12	6.5		6.5								12
14	6.5	6.5	6.5		6.5		5.3		4		14
16	6.5	6.5	6.5	6.3	6.5		5.1		3.9		16
18	6.5	6.5	6.5	6.2	6.4	4.7	5		3.7		18
20	6.5	6.5	6.5	6.1	6.2	4.6	4.8	3.5	3.5	2.5	20
22	6.4	6.5	6.4	5.9	6	4.5	4.6	3.4	3.3	2.4	22
24	5.5	5.7	5.6	5.8	5.7	4.4	4.4	3.3	3.2	2.3	24
26	4.8	5	4.9	5.1	5	4.3	4.2	3.2	3	2.2	26
28	4.3	4.4	4.3	4.5	4.4	4.2	4.1	3.1	2.9	2.1	28
30	3.8	3.8	3.8	4	3.9	4.1	3.9	3	2.7	2.1	30
32	3.3	3.4	3.4	3.5	3.5	3.6	3.5	2.9	2.6	2	32
34	2.9	3	3	3.1	3.1	3.2	3.1	2.8	2.5	1.9	34
36	2.6	2.6	2.7	2.7	2.7	2.9	2.8	2.8	2.4	1.8	36
38	2.3	2.3	2.4	2.4	2.4	2.5	2.5	2.6	2.3	1.8	38
40	2	2	2.1	2.2	2.2	2.3	2.2	2.3	2.2	1.7	40
42	1.8	1.8	1.9	1.9	1.9	2	1.9	2.1	2	1.7	42
46				1.4	1.5	1.5	1.5	1.6	1.5	1.6	46
50							1.1	1.2	1.2	1.3	50
54										1.1	54

主臂长 Boom length(m)	43										主臂长 Boom length(m)
固定副臂长 Fixed jib length(m)	7		10		13		16		19		固定副臂长 Fixed jib length(m)
副臂安装角度 Jib angle(°)	10	30	10	30	10	30	10	30	10	30	副臂安装角度 Jib angle(°)
工作幅度 Working radius(m)											工作幅度 Working radius(m)
12	6.5		6.5								12
14	6.5	6.5	6.5		6.5		5.3				14
16	6.5	6.5	6.5	6.4	6.5		5.1		3.9		16
18	6.5	6.5	6.5	6.2	6.5	4.7	4.9		3.7		18
20	6.5	6.5	6.5	6.1	6.4	4.6	4.8	3.5	3.5		20
22	6.2	6.3	6.3	6	6.2	4.5	4.6	3.4	3.4	2.4	22
24	5.4	5.6	5.5	5.8	5.9	4.4	4.5	3.3	3.2	2.3	24
26	4.7	4.8	4.8	5	5.7	4.3	4.3	3.2	3.1	2.2	26
28	4.1	4.2	4.2	4.4	5.1	4.2	4.1	3.1	2.9	2.2	28
30	3.6	3.7	3.7	3.9	4.5	4	3.8	3	2.8	2.1	30
32	3.2	3.3	3.3	3.4	4	3.5	3.4	3	2.7	2	32
34	2.8	2.9	2.9	3	3.6	3.1	3	2.9	2.6	2	34
36	2.5	2.5	2.5	2.6	3.2	2.8	2.6	2.8	2.5	1.9	36
38	2.2	2.2	2.2	2.3	2.9	2.4	2.3	2.5	2.4	1.8	38
40	1.9	1.9	2	2	2.6	2.1	2.1	2.2	2.1	1.8	40
42	1.7	1.7	1.7	1.8	2.3	1.9	1.8	2	1.8	1.7	42
46			1.3	1.3	1.8	1.4	1.4	1.5	1.4	1.6	46
50						1	1	1.1	1	1.2	50
54										1	54

主要零部件
Main Parts

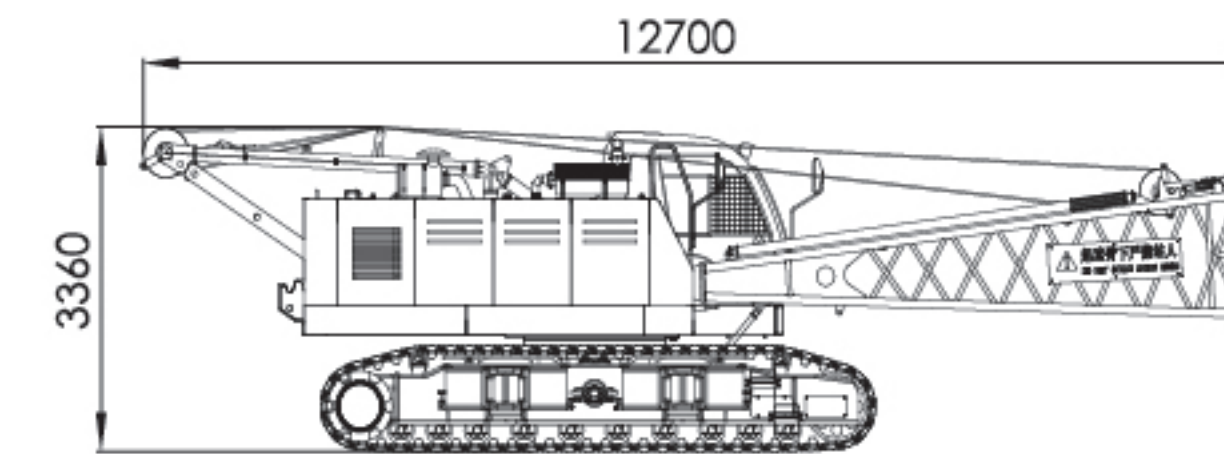

主机运输方案1
Basic machine transport plan 1 ×1

长(L)	12700mm
宽(W)	3460mm
高(H)	3360mm
重量(W)	36.8 t

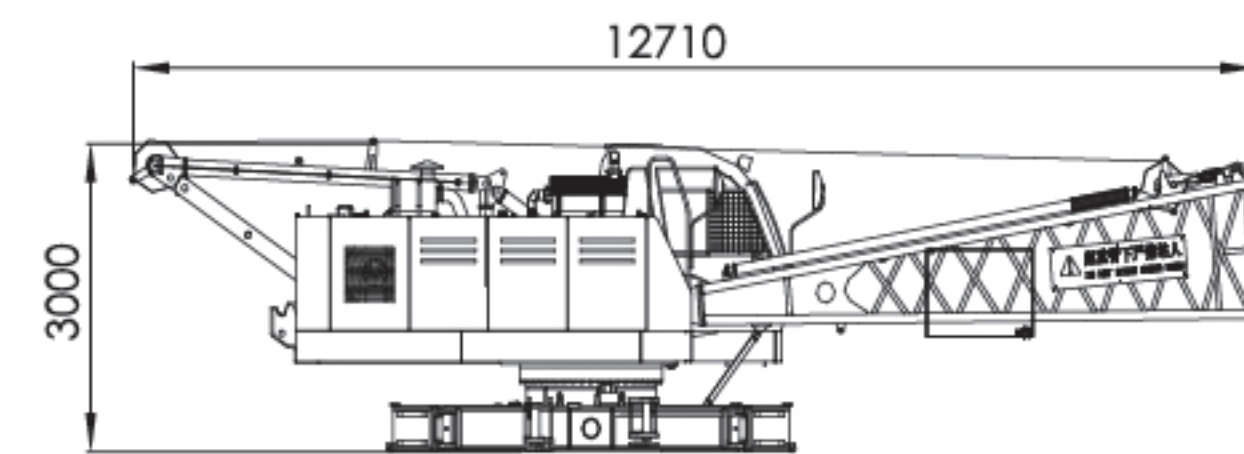

主机运输方案2
Basic machine transport plan 2 ×1

长(L)	1271mm
宽(W)	3460mm
高(H)	3000mm
重量(W)	22.0 t

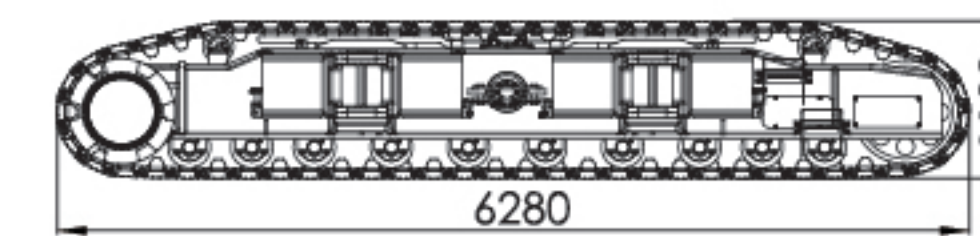

左右履带架
Left/Right track frame ×2

长(L)	6280mm
宽(W)	980mm
高(H)	1100mm
重量(W)	8.51 t

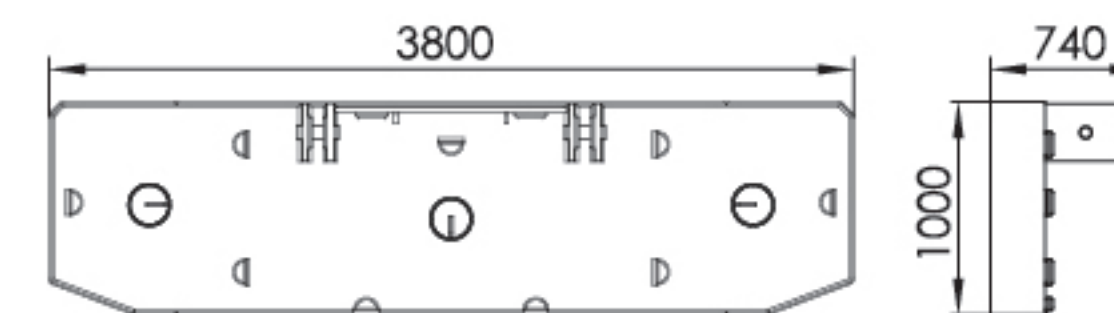

平衡重托盘
Counterweight support ×1

长(L)	3800mm
宽(W)	1000mm
高(H)	740mm
重量(W)	4.0 t

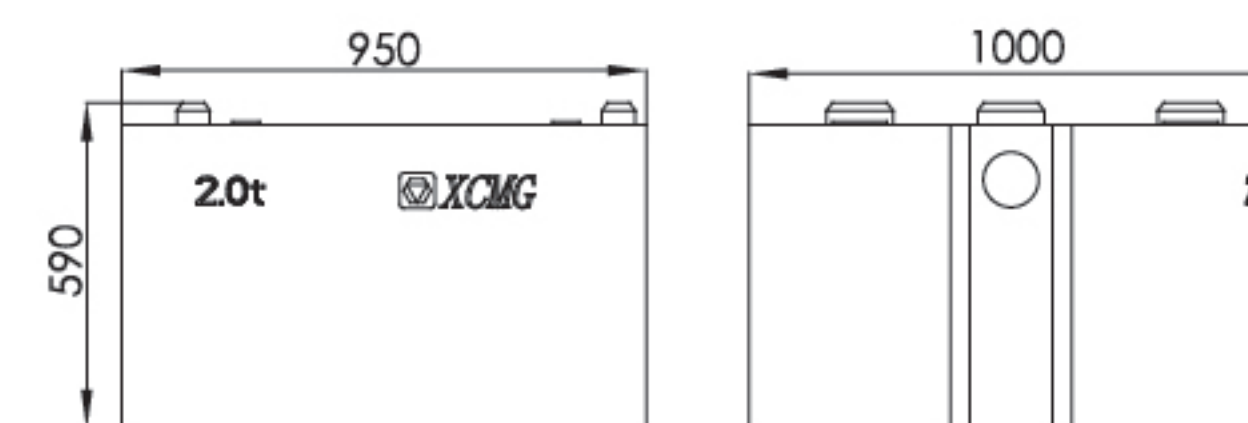

左平衡重块
Left counterweight slab ×3

长(L)	1000mm
宽(W)	950mm
高(H)	590mm
重量(W)	2.0 t

主要零部件
Main Parts

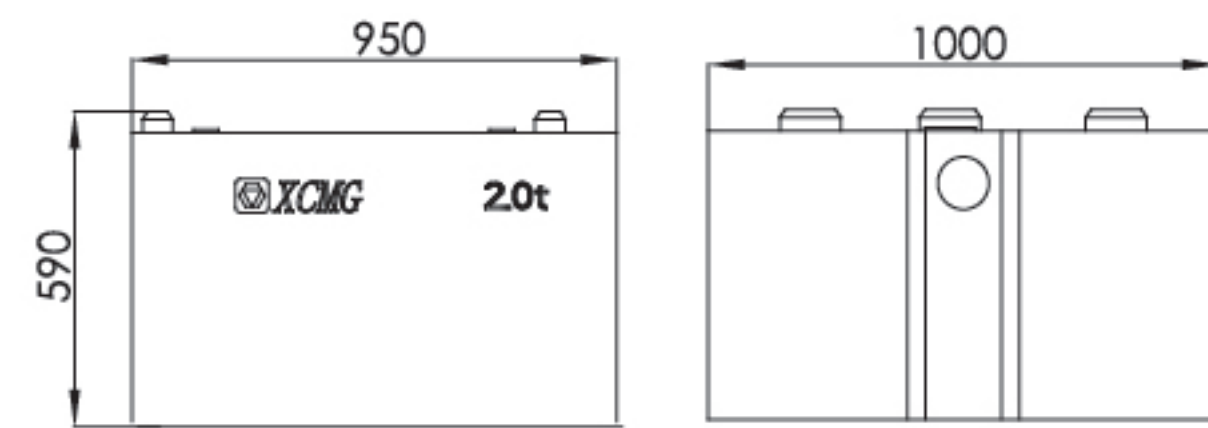

右平衡重块 Right counterweight slab	×3
长(L)	1000mm
宽(W)	950mm
高(H)	590mm
重量(W)	2.0t

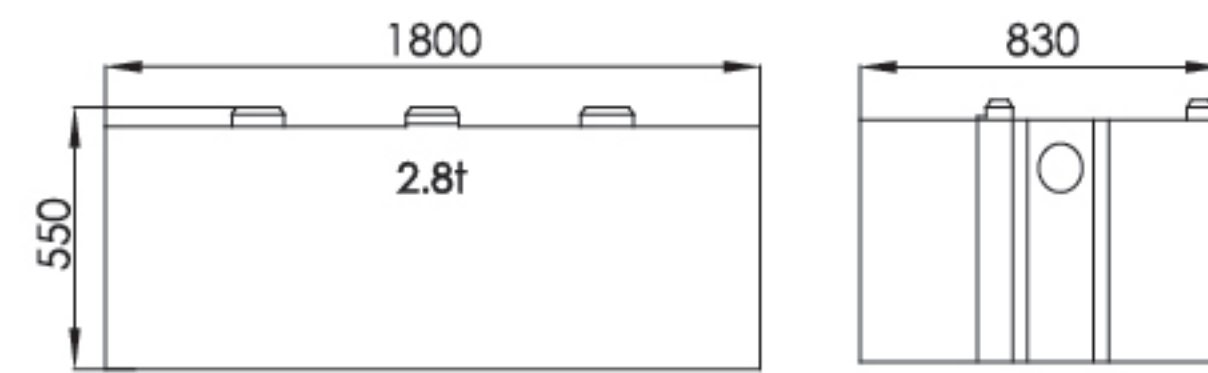

中间平衡重块 Central counterweight slab	×2
长(L)	1800mm
宽(W)	830mm
高(H)	550mm
重量(W)	2.8 t

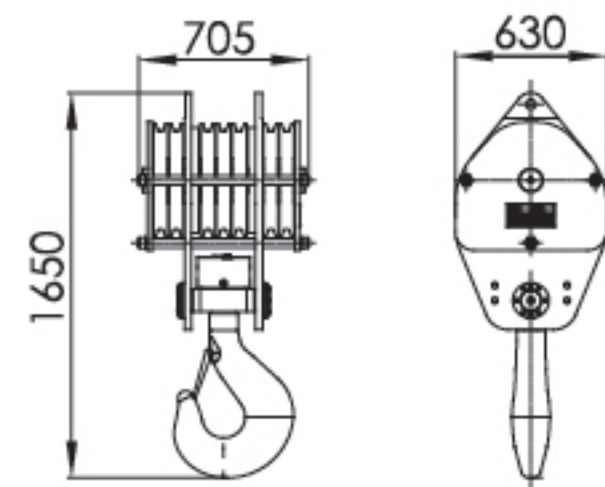

75t吊钩 75t hook block	×1
长(L)	705mm
宽(W)	630mm
高(H)	1650mm
重量(W)	0.89 t

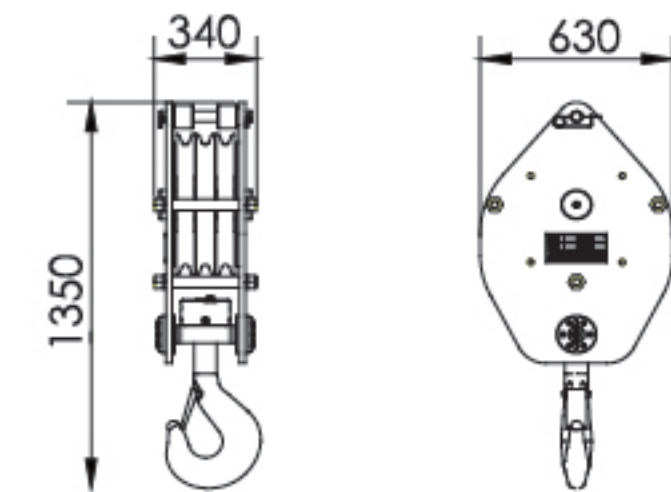

32t吊钩 32t hook block	×1
长(L)	340mm
宽(W)	630mm
高(H)	1350mm
重量(W)	0.35t

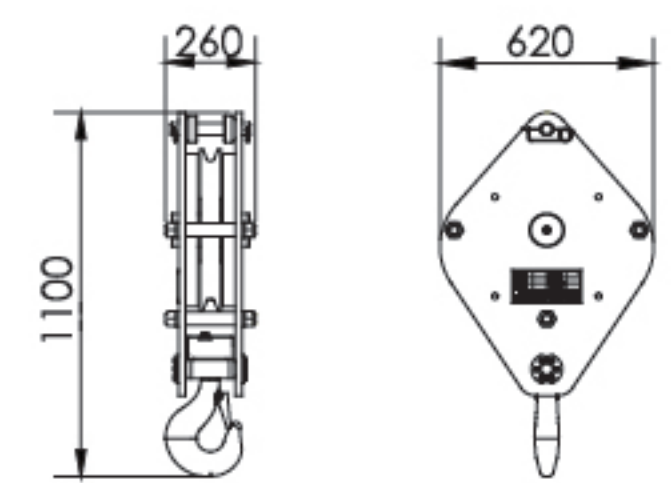

16t吊钩 16t hook block	×1
长(L)	260mm
宽(W)	620mm
高(H)	1100mm
重量(W)	0.28 t

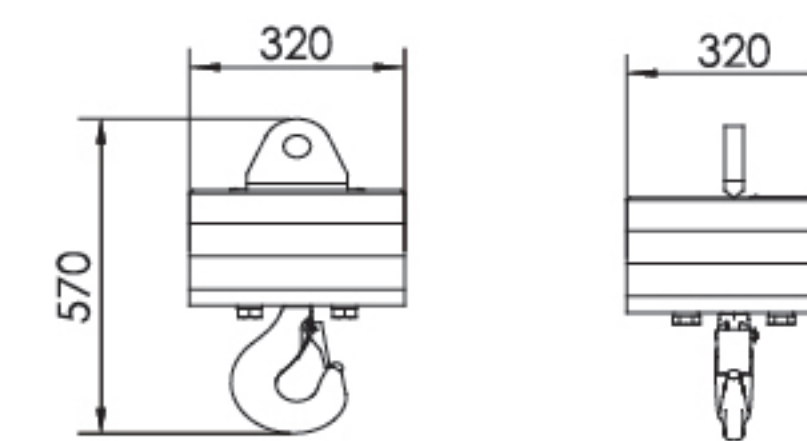

8t吊钩 8t hook block	×1
长(L)	320mm
宽(W)	320mm
高(H)	570mm
重量(W)	0.14 t

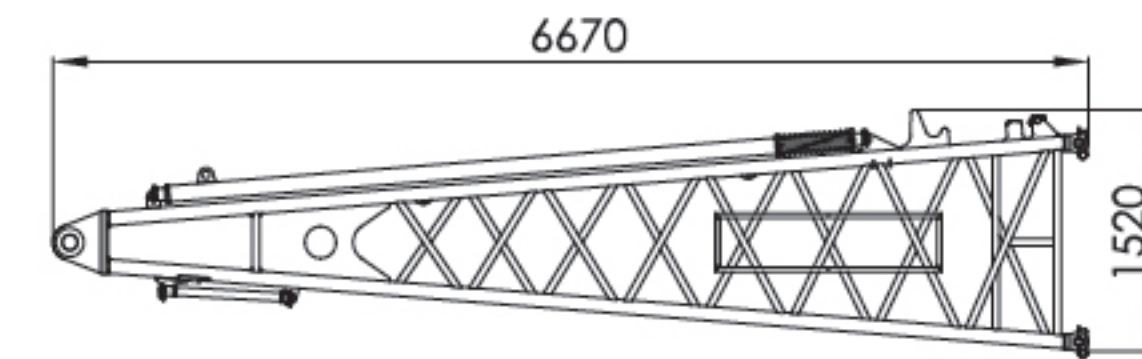

主臂6.5m底节 6.5m boom base	×1
长(L)	6670mm
宽(W)	1600mm
高(H)	1520mm
重量(W)	1.09 t

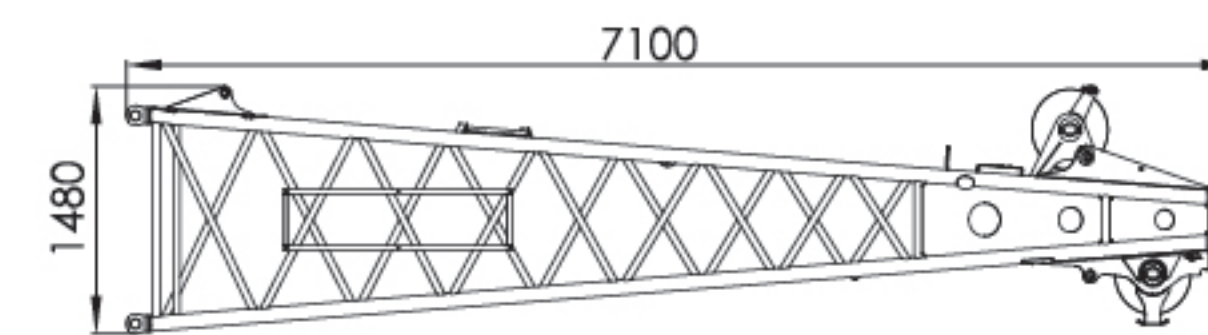

主臂6.5m顶节 6.5m boom top	×1
长(L)	7100mm
宽(W)	1510mm
高(H)	1480mm
重量(W)	0.98t

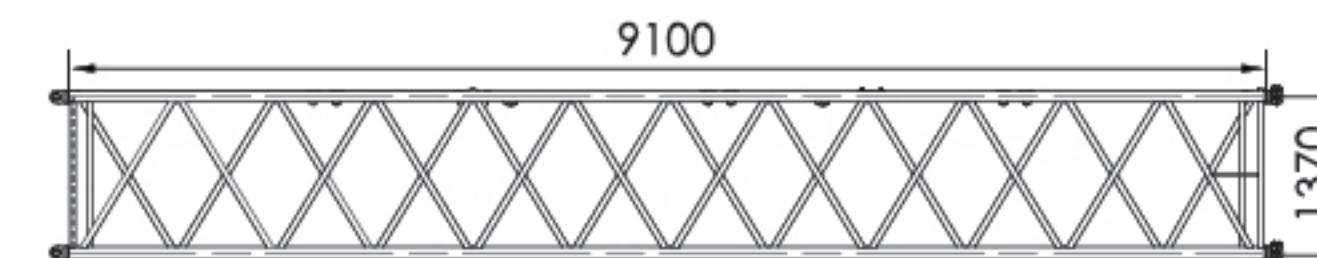

主臂9m中间节 9m boom insert section	×4
长(L)	9100mm
宽(W)	1590mm
高(H)	1370mm
重量(W)	0.78t

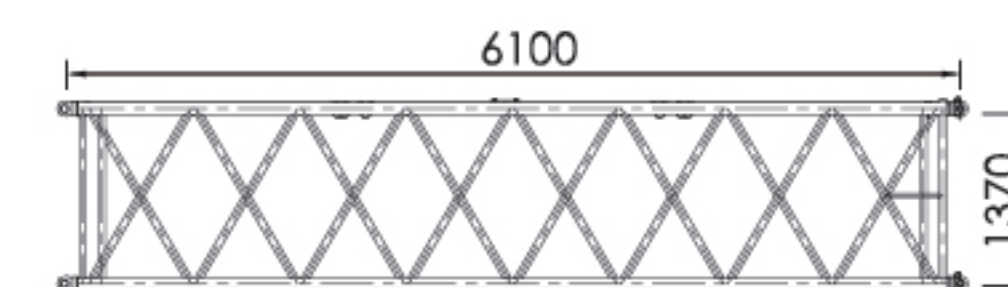

主臂6m中间节 6m boom insert section	×1
长(L)	6100mm
宽(W)	1590mm
高(H)	1370mm
重量(W)	0.54t

主要零部件 Main Parts

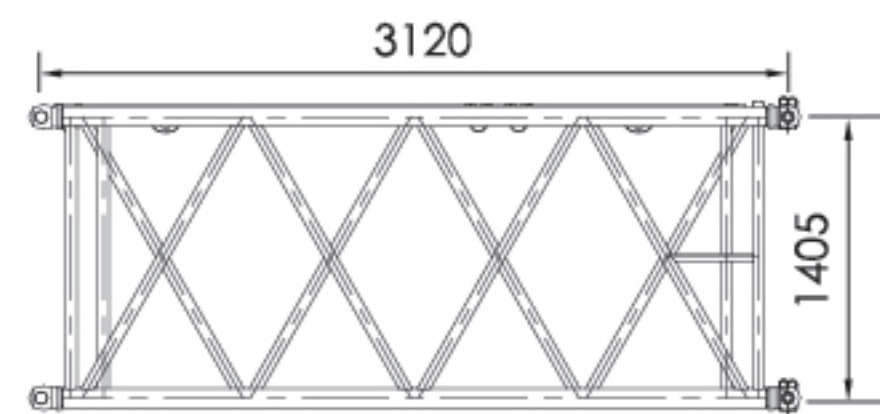

主臂3m中间节 3m boom insert section	×1
长(L)	3120mm
宽(W)	1590mm
高(H)	1405mm
重量(W)	0.32t

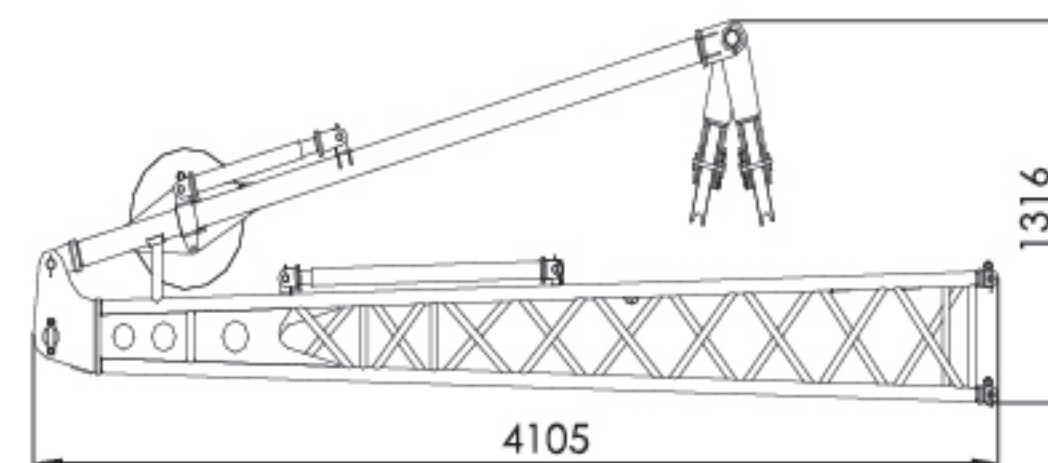

固定副臂底节(含支架) Fixed jib butt (including strut)	×1
长(L)	4150mm
宽(W)	700mm
高(H)	1316mm
重量(W)	0.416 t

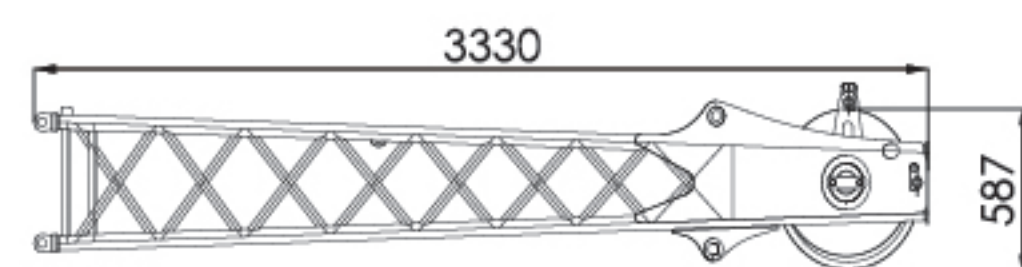

固定副臂顶节 Fixed jib top	×1
长(L)	3330mm
宽(W)	655mm
高(H)	587mm
重量(W)	0.216 t

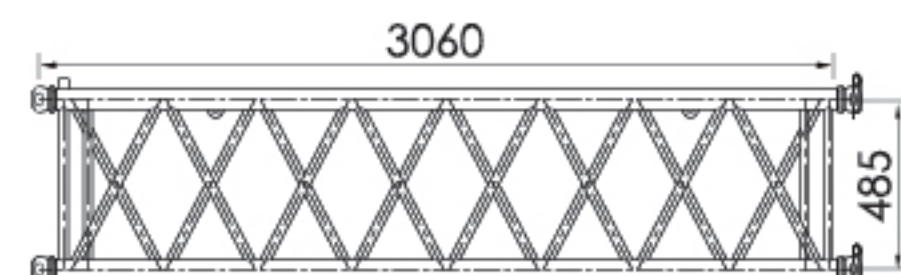

固定副臂3m节 Fixed jib 3m	×1
长(L)	3060mm
宽(W)	655mm
高(H)	485mm
重量(W)	0.104t

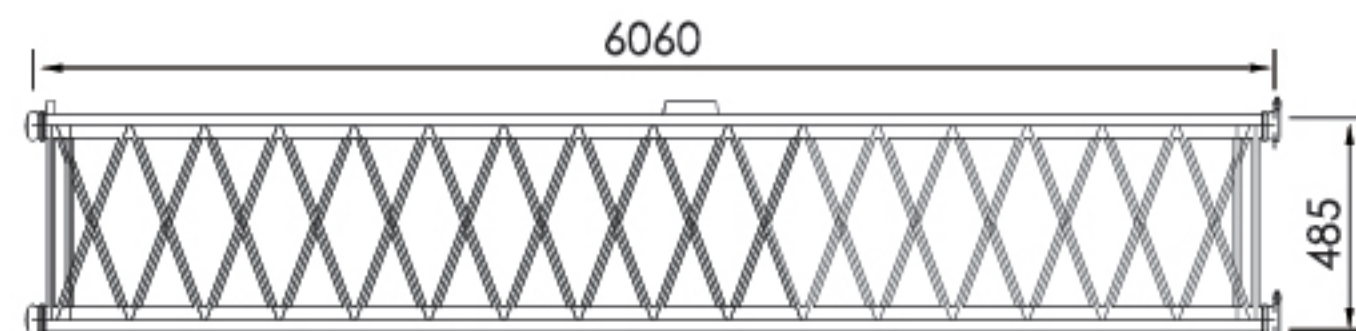

固定副臂6m节 Fixed jib 6m	×1
长(L)	6060mm
宽(W)	655mm
高(H)	485mm
重量(W)	0.192t

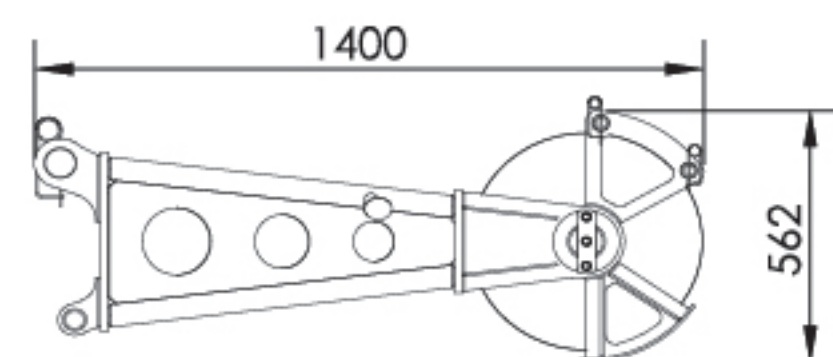

臂端滑轮总成 Boom end pulley assembly	×1
长(L)	1400mm
宽(W)	625mm
高(H)	562mm
重量(W)	0.093t

工作条件及注意 Working Conditions And Cautions

工作条件 Working conditions

1.本起重机的工作条件为：臂长≤50m时风速小于14.1m/s,臂长 > 50m时风速小于9.8m/s，环境温度-20℃~+40℃，地面倾斜度小于1%；

The crane working conditions: boom length ≤50m when wind speed is less than 14.1m/s; boom length > 50m when wind speed is less than 9.8m/s; the ambient temperature is -20℃~+40℃; and the ground gradient is less than 1%.

2.载荷表中的额定起重量，是指在满足给定的工作条件下，重物自由悬挂，在坚实地面缓慢起吊重物,起重机不行走时的最大起重量。作业者须视各种不良条件（如地面松软或不平、风力、侧面负荷、摆动作用、多台起重机合力起吊等）限制或降低起重机的起重量；

The rated lifting load in the chart are the maximum lifting capacity on the condition that the given working conditions are met and the load is in the state of free suspension and lifted slowly from the solid ground. Operators should limit or reduce lifting capacity according to different conditions (such as soft or uneven ground, wind force, side loading, oscillating action, several crane cooperate-lifting).

3.载荷表中额定起重量包括主吊钩、钢丝绳和其它所有吊具的重量，各吊钩及臂端单滑轮的重量见下表：

The rated lifting capacity in the chart includes the weight of main hook block, wire rope and all slings. The weight of each hook block and boom single top is shown in the table below:

75t吊钩 75t hook block	32t吊钩 32t hook block	16t吊钩 16t hook block	8t吊钩 8t hook block	臂端单滑轮 Boom single top
0.89吨 ton	0.35吨ton	0.28吨ton	0.14吨ton	0.093吨ton

4. 载荷表中没有列出额定载荷值的空白区为非工作区，起重机不允许在该区域内进行起重作业；

The blank area of the chart where no rated lifting load listed is regarded as non-operation area, so crawler crane is not allowed to carry out lifting operation in this area.

5. 表中起重量为带全配重的起重重量；

The lifting load in the chart includes the lifting capacity of full counterweight.

6. 本机允许带载低速行驶，主臂工况、臂端单滑轮工况可带90%额定载荷直线行走，固定副臂工况可带50%额定载荷直线行走；

This crawler crane is allowed to travel slowly with a suspended load, boom and boom single pulley working mode the maximum load weight is 90% of rated lifting load given in the load chart; fixed jib working mode the maximum load weight is 50% of rated lifting load given in the load chart for the crane travel.

7. 吊钩及倍率的选取

Selection of hook block and parts of line.

在任何情况下，吊钩的选取必须满足吊钩的额定起重量大于或等于实际吊重量（包括钢丝绳及吊具等）

In any case, the selection of hook block must satisfy that the hook block rated lifting load is more than or equal to the actual lifting load (including wire rope, slings and etc.).

倍率按下表选取：

Parts of line is according to the table below:

倍率Parts of line	1	2	3	4	5	6	7	8	9	10	11	12
最大起重量Max. lifting load	6.5	12.7	18.9	25.0	31.0	37.0	42.9	48.6	54.3	60.0	66.0	75.0

单倍率用于臂端单滑轮。

The one part of line is used for boom single top