

Introduction on the Highlights of XGC100A Crawler Crane

★ Safe and reliable control system

The two operation modes (working mode and assembly mode) are convenient and reliable; emergency electrical control system, safety and monitoring devices are complete. The hydraulic main valve with high level of integration simplifies hydraulic pipeline and greatly reduces the failure points. The multiple filtration system can effectively prevent the emulsification of hydraulic oil and prolong the service life of hydraulic components.

★ Excellent operation performance and high working efficiency

Innovative use of micro control adjustment technology can greatly improve the stability and accuracy of crane movements. With rich compound movements and ideal single line speed, the operation is easy and efficient.

★ Strong lifting capacity

The Max. lifting capacity of main boom is 100t/4m, the Max. lifting capacity of jib is 12t/18m. Max. boom length is 61m, and the longest boom and fixed jib combination is 52m+19m.

★ Rich working conditions and easy interchange between the various conditions

This crane is configured with various working conditions such as boom working condition, boom working condition with boom single top and hook block, boom working condition with fixed jib and hook block, fixed jib working condition, fixed jib working condition with boom main hook, boom single top working condition with boom main hook and etc. to meet different lifting requirements. The switch between main hook and auxiliary hook is realized through one button.

★ Convenient disassembly and maintenance function

This crane is equipped with gantry self-erection function, so the gantry can raise by itself without the use of auxiliary crane. The pin shafts for boom sections are designed with two sharp points and double chamfer, which makes boom disassembly more efficient; Spacious hood, large maintenance space, the daily maintenance of the crane more convenient.

★ **Flexible counterweight combination**

Load charts with different counterweight combinations are provided, the crane can also lift load with counterweight not installed. Users can choose counterweight quantity according to their needs, with higher adaptability to the working site and more economical.

★ **Modular design of crane components**

Fixed jib, boom single top, counterweight and hook block of XGC series products below 100 tons are shared with each other, which can greatly reduce the cost of purchasing XGC series products.

★ **Optimized transportation design**

After structural optimization and integration, the transportation of this crane only needs three transport vehicles, lower the transport cost. The standard configuration of lengthened outrigger cylinders is unique in the industry, meeting the requirement of 1.2m fat-bed trailers.

XGC100A Crawler Crane Technical Specification

Crawler crane model: XGC100A

Max. rated lifting capacity: 100t/4m

Max. rated load moment: 425t.m

Max. boom length in main boom working condition: 61m

Max. boom combinations in boom single top working condition: boom 61m+boom single top 1.1m

Max. boom and jib combinations in fixed jib working conditions: boom 52m+fixed jib 19m

Max. weight of single unit for transport: 24.1t

Max. width of single unit for transport: 3.4m

Max. height of single unit for transport: 3.04m

I. Parts and system description of the crane

I) Crane superstructure

1. Boom combination

The boom sections of XGC100A crawler crane use high-strength seamless pipe as chords and lacing members, supplemented by four-chord lattice structure which is welded by high strength steel plate, with equal section in the middle and variable section at two ends. With the help of accurate finite element analysis and calculation, the potential of boom sections are fully utilized and the lifting capacity is greatly improved.

In boom working condition, the maximum lifting capacity is 100t/4m, maximum load moment is 425t.m, boom length 13m~61m. Boom composition: boom butt 1×6.5m, boom top 1×6.5m, boom insert 2×3m, boom insert 1×6m, boom insert 4×9m.

In fixed jib working condition, the maximum lifting capacity is 12.0t (parts of line 2), maximum load moment is 242t.m, boom length 31m~52m, fixed jib length 7m~19m. Fixed jib composition: jib butt 1×4m, jib top 1×3m, jib insert 1×3m, jib insert 1×6m, strut 1×3m.

In boom single top working condition, the maximum lifting capacity is 8t (parts of line 2), boom

single top length is 1.1m, boom length 13m~61m.

2. Boom luffing components

Luffing connection between boom sections is mainly realized through guy cables, supplemented by pendant. The guy cables adopt mature technology structure, safe and reliable; the pendants use high-strength steel plate and cut once for formation, no welding, with less manufacturing defects and has high safety factor.

3. Turntable

Turntable is the key load bearing structure to connect superstructure and undercarriage, the main bearing structure is made of high strength steel plate and welded in flat box-type structure, the space is enlarged by welding bracket on both sides for arranging the fixed load. Turntable is connected with undercarriage by slewing ring. Boom butt, gantry, hoist winch, luffing winch and counterweight are arranged on the main bearing structure; fixed load such as cab, engine system, main pump, hydraulic valve, electric cabinet and other structures are arranged on the brackets on both sides; turntable main structure and brackets of both sides are design according to the force condition of the overall crane, with reasonable structure, good overall strength and stiffness.

4. Gantry

Gantry is double-limb structure, reinforced beam is installed between the two limbs, with good stability. The main structure of gantry is high-quality seamless steel pipe, with less welding, less manufacturing defects and high safety factor. There are two states for the gantry, it is erected for working and laid down for transportation. The gantry is equipped with self-erection roller, which can achieve self-erection function in coordination with boom butt.

5. Mechanism composition

The mechanisms of the crane and their functions are shown in the table below:

No.	Name	Function	Location
1	Main hoist system	Used for the lifting operation of main boom	Turntable middle and front side
2	Auxiliary hoist system	Used for auxiliary lifting operation in boom single top and fixed jib working	Turntable middle side

		conditions	
3	Main luffing system	Boom luffing	Turntable rear side
4	Slewing system	Superstructure slewing	Turntable middle side
5	Travel unit	Crane travel	Crawler drive sprocket

6. Hoist system

Hoist system includes main hoist system and aux. hoist system.

For main and aux. hoist systems, planetary reducer is driven by fixed displacement motor to achieve the hoisting and lowering of main or auxiliary hook block through drum and pulley block. The speed of main and auxiliary hoist winches is increased through double-pump soil supply function.

The hoist mechanisms have built-in planetary reducer, with negative brake wet type multi-disc normally closed brake, to achieve “spring braking/hydraulic release” function, safe and reliable. Splash lubrication is adopted, free for maintenance. The hoist winches also have the features of easy oil replacement, low noise, high efficiency and long service life. Meanwhile it also has excellent micro speed performance.

The ductile iron double-line drum is used for the winches, with good vibration absorption, ensures that there is no messy rope when it is reeved in multiple layers, which effectively prolong the rope’s service life.

The rotation resistance wire rope used for main hoist system is left-handed and twisting in the same direction. It has the features of independent steel core, high breaking force and high extrusion resistance. Rated single line pull is 8t, rope diameter is $\phi 22$ mm, rope length is 240m.

The wire rope used for auxiliary hoist system is also rotation resistance, with the features of independent steel core, high breaking force and high extrusion resistance. Rated single line pull is 8t, rope diameter is $\phi 22$ mm, rope length is 155m.

7. Luffing system

For the luffing winch system, planetary reducer is driven by fixed displacement hydraulic motor to achieve boom luffing through drum and luffing pulley block. Main luffing mechanism has built-in planetary reducer, with negative brake wet type multi-disc normally closed brake to achieve “spring braking/hydraulic release” function.

The ductile iron double-line double-drum is used for main luffing winch, with good vibration absorption, ensures that there is no messy rope when it is reeved in multiple layers, which effectively prolong the rope's service life. The drum has a ratchet locking device, and the pawl is driven by hydraulic cylinder to achieve multiple lock for protection.

The rotation resistance wire rope used for the luffing system is left-handed and twisting in different directions. It has the features of independent steel core, high breaking force and good structure stability. Rated single line pull is 6t, rope diameter is $\phi 20$ mm, rope length is 140m.

8. Slewing unit

Slewing unit is internally meshed with slewing ring for drive. It is arranged in front of turntable. Planetary reducer is driven by fixed displacement motor to drive the slewing ring to achieve 360° slewing.

Slewing unit has a built-in planetary reducer, with negative brake wet type multi-disc normally closed brake to achieve “spring braking/hydraulic release” function, so as to ensure high brake safety. Slewing unit also has a mechanical locking device for locking protection of the slewing unit.

Eccentric mechanism can ensure a better meshing between the reducer and slewing bearing, so the slewing is more stable. The slewing mechanism has free swing function, so when heavy load is lifted, the side force of boom can be eliminated even if the hook is not on the vertical center line of the gravity center of the heavy load, so as to prevent boom from being damaged due to large side force.

9. Slewing ring

Single-row ball type slewing bearing, with the features of large bearing capacity and small rotary resistance.

10. Cylinder assembly

It includes track frame telescopic cylinder, car-body outrigger cylinder and boom luffing ratchet lock cylinder.

11. Operator's cab

Operator's cab of the new generation is designed by ergonomic principle, it is very large with width of 1.25m. It has the features of full-light design, gorgeous appearance, wider vision, spacious and comfortable space, comfortable and convenient operation. The inside of the cab is equipped with 10.4-inch large touch screen and integrated key panel, with full sense of technology.

The model of cab adopts the method of bionic design, with smooth lines and a sense of power. The glass area is larger and the distribution of side glass is more reasonable, with stronger sense of technology and wider field of view. The interior is arranged by the concept of human-centered, so the driver can touch all the buttons without leaving the seat. The cab is also set with adjustable seat, air conditioning, power socket, radio and so on to provide the operator with a comfortable operating environment.

II) Crane undercarriage

Crane undercarriage comprises car-body, track frame and crawler travel unit. Car-body and track frame are inserted for connection. The extension and retraction of track frames are realized through hydraulic cylinder.

1. Car-body and outrigger

Car-body uses high strength steel, box-type structure, with cross panel installed in the middle to strengthen its stiffness of torsion resistance, simple structure, high load bearing, and good rigidity.

Outrigger cylinder is used for the assembly, disassembly and transportation of the crane, it is articulated to car-body outside by pin shaft.

2. Track frame

Track frame consists of track beam, drive sprocket, idler roller, upper roller, lower roller and track shoe. Track beam is box-type structure, the connection part with car-body is strengthened partially, and cross panel is installed in the middle of it. Two track frames are symmetrically arranged, and the four rollers and track beam are welded by high strength alloy steel, the track shoe width is 0.85m.

3. Crawler travel unit

The travel crawler unit adopts built-in planetary gear reducer, driven by axial plunge variable motors. The reducer is with hydraulic release travel brake, safe and reliable. The two travel gears (left and right) can be operated synchronously or separately to realize straight travel and turning around.

III) Hydraulic system

Adopt hydraulic pilot proportional controlled LUDV load sensing system, it can achieve load independent flow distribution, with accurate speed, sensitive operation, good stability and good fine motion performance. LUDV integrated main valve can achieve the compound operation of multiple movements, compact in structure and easy for maintenance.

Main hoist winch and aux. hoist winch are with double pump confluence function, easy to achieve high/low speed control of the winches. Specialized slewing buffer circuit, the start and stop of slewing is smooth and soft, meeting the requirements of fine lifting operation.

Fuel tank capacity: 400L.

IV) Electrical system

Electrical system mainly includes the following components: engine control, monitoring instruments, auxiliary equipment, hydraulic system control, load moment limiter, and safety control.

Electrical system composition: conventional electrical system and PLC control system.

Conventional electrical system adopts 24V parallel circuit, and the wiring of electrical equipment adopts single wire system. The system includes power supply, starting control, cab air conditioner and radio, illumination (lighting), wipers and etc.

The PLC control system includes the control of main winch, aux. winch, slewing, slewing, boom luffing and other movements, as well as engine condition monitoring. All movements are controlled by hydraulic proportional control technology. Through PLC logic control, it can effectively ensure the realization of all functions of the crane, and fully reflect the people-oriented design concept.

V) Engine system

Model: Weichai WP7G270E301;

Rated output power: 199kW/2000rpm;

Maximum torque / maximum torque speed: 1200N•m/1200-1500rpm;

Environmental protection: in compliance with China III emission standard;

Fuel tank capacity: 400L.

VI) Counterweight

Turntable counterweight is 34t in total, installed at the rear side of turntable. It is connected with turntable by pin shafts.

Counterweight composition: counterweight tray 1×7t, left and right counterweight block 6×3.5t, middle counterweight block 2×3t.

VII) Hook block

Four kinds of hook blocks are provided for customers to choose according to their needs, see the hook block configuration in table below:

Name	100t	55t	35t	8t
Weight (t)	0.96	0.62	0.46	0.25
Number of pulley	7	5	3	-
Max. parts of line	14	6	5	1

II. Safety protection measures

This crane widely uses mechanical, electronic and hydraulic and other safety and warning devices to ensure the safe use of the machine. The safety devices include: load moment limiter, slewing lock device, boom backstop device, hoist limit switch, boom angle limiter, anemometer, slewing warning and hydraulic system relief valve, balance valve and etc.

1. Mode switch

In assembly mode, over-wind protection device, boom angle limiter and load moment limiter are all out of service to provide convenience for crane assembly; in working mode, all safety devices are working normally.

2. Emergency stop button

Press this button in emergency condition to stop all crane movements.

3. Rope over-wind protection device

There is an over-wind device on boom head to prevent rope from being over-wound. When the rope is hoisting to a certain height, the over-wind indicator light on display will turn on, at the same time, the movement of hoisting up will be stopped by LMI automatically.

4. Rope over-release protection device

Rope end limiter is set on main and aux. hoist winches to prevent wire rope from over-releasing. When there are only three loops of rope left, the over-release indicator light on display will turn on, at the same time, the movement of lowering down will be stopped by LMI automatically.

5. Ratchet locking device

Ratchet locking device is used to lock the luffing winch so that boom is stopped and placed safely at non-working state.

6. Mechanical safety device

Slewing locking device is used to lock superstructure slewing when the crane is stopped; backstop devices are used to prevent boom and jib strut from tilting backward.

7. Boom angle limiter

When boom is raised to a specified angle, boom raising is stopped under the control of load moment limiter and hoist limit switch. When boom angle is less than the specified value, boom lowering is stopped under the control of load moment limiter and gives a warning sound.

8. Hook latch

All hook blocks are equipped with hook latch to prevent the hanging rope on the hook head from falling.

9. Hydraulic system safety protection device

Hydraulic system is equipped with hydraulic balance valve, hydraulic relief valve and other devices to ensure the stable and safe work for the system.

10. LMI system (Hirschmann)

Detection function: LMI can automatically detect parameters such as boom angle and lifting weight.

Display function: 7.0-inch color LCD display, show important parameters in lifting operation through text (Chinese or English) and graphics, such as load moment percentage, actual lifting weight, rated lifting weight, radius, boom length, angle, maximum lifting height, working condition code, parts of line, limit angle and information code.

Warning function: with complete pre-alarm and overload stop function. If it is detected that the actual weight exceeds the rated lifting capacity or boom angle exceeds the maximum value, LMI will send alarm and limit the current movement of the crane.

The system has self-diagnosis function.

11. Tricolor warning light

The light comprises three colors. When crane loading is below 90% of the rated capacity, the “green

light” is on to indicate that the crane is operating in a safe area; when crane loading is below 90%~100% of the rated capacity, the “yellow light” is on to indicate that the crane is close to the rated load; when crane loading exceeds 100% of the rated capacity, both “red light” and “yellow light” will be on to indicate that the crane is overloaded and in the dangerous area, the control system will automatically cut off crane movement to dangerous direction.

12. Audio and video alarm

When crawler crane is moving and slewing, there is light and sound for warning.

13. Illumination light

There is illumination lamp at front of turntable, on boom and inside the cab for night operation.

14. Rearview mirror

It is located outside the operator’s cab, so that the driver can easily observe the situation behind the machine.

15. Height mark lamp

It is located on boom tip for high level operation warning.

16. Anemometer

It can detect the current wind speed and send signal to the monitor in operator’s cab to remind the operator for safe operation in wind load.

17. Level gauge

Level gauge is equipped to display the ground gradient, so as to provide crane levelness for the operator.

III. Main parts list

No.	Part name		Manufacturer
1	Power system	Engine	Weichai
2	Hydraulic system	Main winch	Motor
			Reducer
			Balance valve
			Liyuan or other equally famous brand
			Zhuzhou Gear or other equally famous brand
			Rexroth

		Aux. winch	Motor	Liyuan or other equally famous brand
			Reducer	Zhuzhou Gear or other equally famous brand
			Balance valve	Rexroth
		Luffing winch	Motor	Liyuan or other equally famous brand
			Reducer	Zhuzhou Gear or other equally famous brand
			Balance valve	Rexroth
		Slewing	Motor	Liyuan or other equally famous brand
			Reducer	Zhuzhou Gear or other equally famous brand
		Travel	Motor	Liyuan or other equally famous brand
			Reducer	Zhuzhou Gear or other equally famous brand
		Pump group	Main pump	Liyuan or other equally famous brand
			Slewing pump	Sichuan Changjian
		Valve group	Main valve	Huade or other equally famous brand
		3	Electrical system	Load moment limiter
4	Slewing unit	Slewing bearing		Tongli
5	Travel device	Drive sprocket	Quantity: 2	Jining Yongsheng
		Idler	Quantity: 2	Jining Yongsheng
		Upper roller	Quantity: 4	Jining Yongsheng
		Lower roller	Quantity: 22	Jining Yongsheng
		Crawler shoe	Quantity: 136	Jining Yongsheng

IV. Main technical parameters

1. XGC100A crawler crane outline drawing

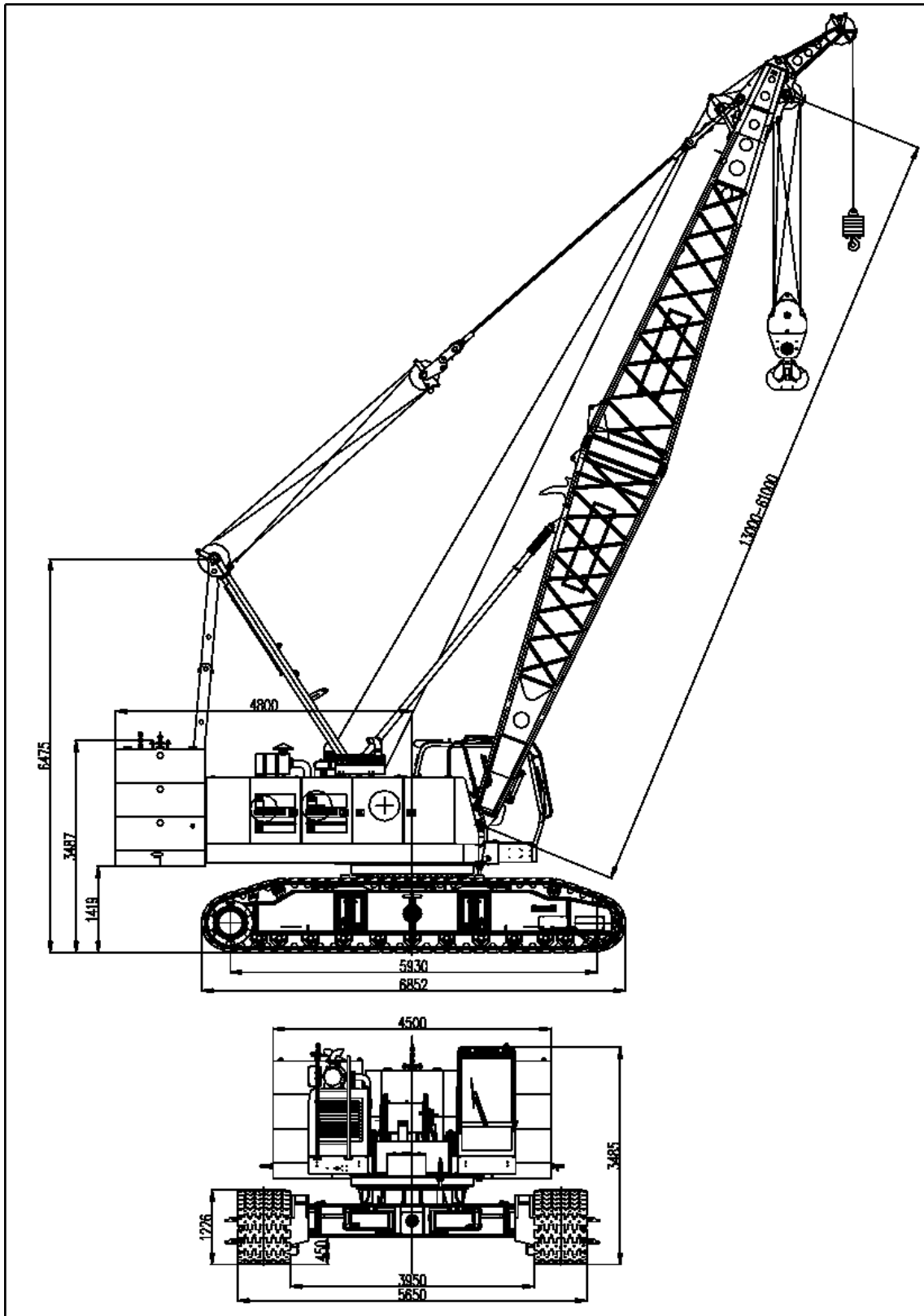

2. XGC100A crawler crane main technical parameters

Item		Unit	Parameters
Max. rated lifting capacity	Boom working condition	t	100
	Boom single top working condition	t	8
	Fixed jib working condition (without main hook)	t	12
	Fixed jib working condition (with main hook)	t	12
Max. load moment	Boom working condition	t·m	425
	Fixed jib working condition	t·m	242
	Boom single top working condition	t·m	224
Dimension	Boom length	m	13~61
	Boom luffing angle	°	-3~80.5
	Fixed jib length	m	7~19
	Angle between boom and fixed jib	°	10, 30
	Boom single top	m	1.1
Speed	Hoist winch max. single line speed	m/min	120
	Boom luffing winch max. single line speed	m/min	70
	Max. slewing speed	rpm	1.8
	Max. travel speed	km/h	1.0
Engine	Engine model	-	WP7G270E301
	Engine rated power and speed	kW/rpm	199/2000
	Emission standard	-	EURO IIIA
Total vehicle mass (with 13m basic boom and 100t hook block)		t	81.2
Mean ground pressure		MPa	0.079
Grade-ability		-	30%

Max. weight of single unit for transport	t	24.1
Max. dimension of single unit (turntable) for transport (L×W×H)	m	13.04×3.4×3.04

Notes:

1. Single line speed is the calculated value of the rope on the drum most outside layer with engine idle running, which changes according to different load and working conditions.
2. Travel speed and slewing speed are the theoretical values for the crane located on level and solid ground, with 13m basic boom, 100t hook block, no load and 31t turntable counterweight.
3. We reserve the right to improve and update the technical specifications without prior notice.

V. Typical working conditions

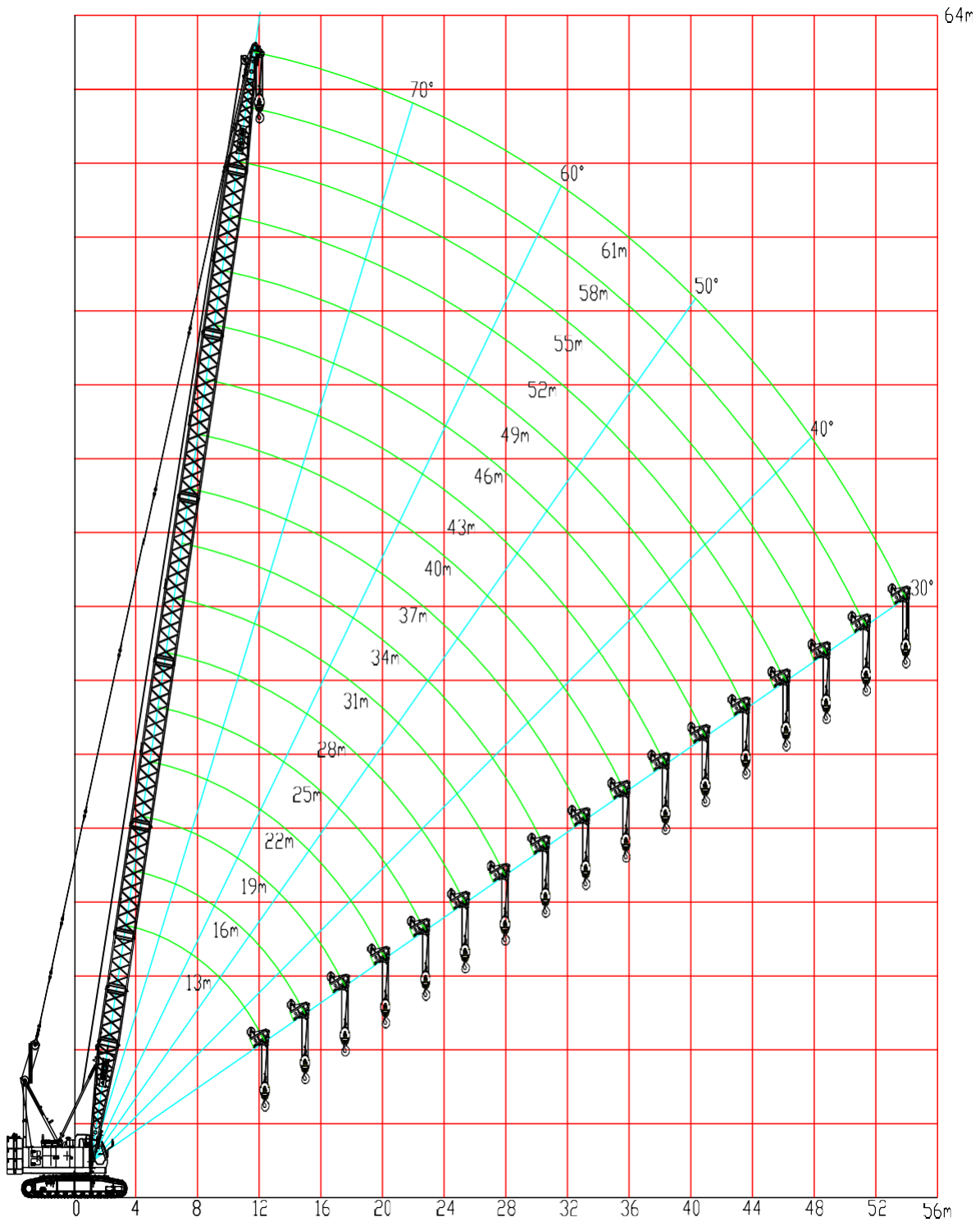

Crane working range: main boom working condition

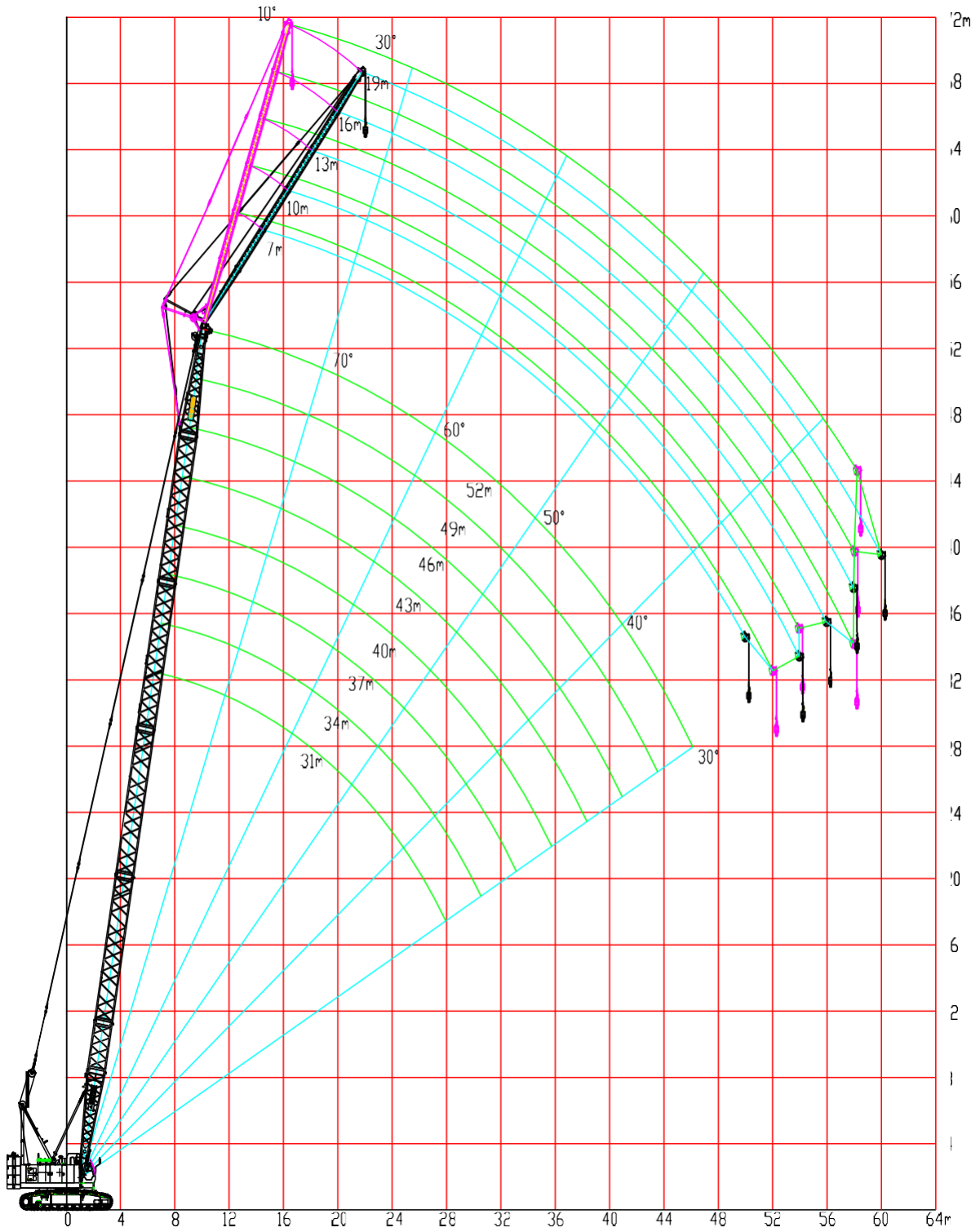

Crane working range: fixed jib working condition (offset angle 10° and 30°)

5.1 XGC100A Boom lifting capacity tables (without boom single top and hook block)

Table 1-1 XGC100A Boom lifting capacity tables (without boom single top and hook block) Unit: t									
Rear counterweight 34t									
Radius (m)	Boom length (m)								
	13	16	19	22	25	28	31	34	37
4	100.0**								
5	84.9*	81.5*	77.1*						
6	67.3*	64.5*	61.6*	62.6	60.0				
7	52.4*	52.3*	54.4	52.4	50.4	48.6	47.0		
8	42.7*	45.3	45.3	44.9	43.4	42.1	41.0	39.4	38.2
9	38.3	38.2	38.1	38.1	38.0	37.0	35.9	34.9	33.9
10	33.0	32.9	32.9	32.8	32.7	32.6	32.0	31.1	30.3
12	25.8	25.7	25.6	25.5	25.4	25.4	25.3	25.1	25.0
14		20.9	20.9	20.8	20.7	20.6	20.5	20.4	20.3
16			17.5	17.4	17.3	17.2	17.1	17.0	16.9
18				14.9	14.8	14.7	14.6	14.5	14.4
20				13.0	12.9	12.8	12.7	12.5	12.4
22					11.3	11.2	11.1	11.0	10.9
24						10.0	9.9	9.7	9.6
26							8.8	8.7	8.6
28							7.9	7.8	7.7
30								7.0	6.9
32									6.3

※ The area with “**” shall use 27t rear counterweight, the area with “*” shall use 31t rear counterweight

Table 1-1 XGC100A Boom lifting capacity tables (without boom single top and hook block) Unit: t

Rear counterweight 34t

Radius (m)	Boom length (m)							
	40	43	46	49	52	55	58	61
9	33.0	31.6						
10	29.5	28.7	26.9	23.5				
12	24.3	23.7	23.1	22.5	19.7	17.4	15.4	
14	20.2	20.0	19.6	19.1	18.6	16.6	14.7	13.1
16	16.8	16.6	16.5	16.4	16.1	15.7	14.1	12.5
18	14.3	14.1	14.0	13.9	13.7	13.6	13.3	12.0
20	12.3	12.2	12.1	11.9	11.8	11.7	11.5	11.3
22	10.8	10.6	10.5	10.4	10.2	10.1	9.9	9.8
24	9.5	9.3	9.2	9.1	9.0	8.8	8.7	8.5
26	8.5	8.3	8.2	8.1	7.9	7.8	7.6	7.4
28	7.6	7.4	7.3	7.2	7.0	6.9	6.7	6.5
30	6.8	6.6	6.5	6.4	6.3	6.1	6.0	5.8
32	6.2	6.0	5.9	5.8	5.6	5.5	5.3	5.1
34	5.6	5.4	5.3	5.2	5.0	4.9	4.7	4.5
36		4.9	4.8	4.7	4.5	4.4	4.2	4.0
38		4.5	4.3	4.2	4.1	3.9	3.8	3.6
40			3.9	3.8	3.7	3.5	3.4	3.2
42				3.5	3.3	3.2	3.0	2.8
44					3.0	2.8	2.7	2.5
46					2.7	2.5	2.4	2.2
48						2.3	2.1	1.9
50							1.8	1.6
52								1.4

5.2 XGC100A Boom lifting capacity tables (with boom single top and hook block)

Table 2-1 XGC100A Boom lifting capacity tables (with boom single top and hook block) Unit: t						
Rear counterweight 0t						
Radius (m)	Boom length (m)					
	13	16	19	22	25	28
4	43.0					
5	30.6	28.7	27.1			
6	23.6	22.3	21.2	20.2	19.2	
7	18.2	18.1	17.3	16.6	15.8	15.1
8	14.6	14.5	14.5	13.9	13.3	12.8
9	12.0	11.9	11.9	11.8	11.4	11.0
10	10.2	10.1	10.0	10.0	9.9	9.5
12	7.6	7.5	7.4	7.3	7.2	7.2
14		5.8	5.7	5.6	5.5	5.4
16			4.5	4.4	4.3	4.2
18				3.5	3.4	3.3
20				2.8	2.7	2.6
22					2.1	2.1
24						1.6

5.3 XGC100A Boom single top lifting capacity table (with boom hook)

Table 3-1 XGC100A Boom single top lifting capacity table (with boom hook) Unit: t									
Rear counterweight 34t									
Radius (m)	Boom length (m)								
	13	16	19	22	25	28	31	34	37
5	8.0*	8.0*							
6	8.0*	8.0	8.0	8.0					
7	8.0	8.0	8.0	8.0	8.0	8.0			
8	8.0	8.0	8.0	8.0	8.0	8.0	8.0	8.0	
9	8.0	8.0	8.0	8.0	8.0	8.0	8.0	8.0	8.0
10	8.0	8.0	8.0	8.0	8.0	8.0	8.0	8.0	8.0
12	8.0	8.0	8.0	8.0	8.0	8.0	8.0	8.0	8.0
14		8.0	8.0	8.0	8.0	8.0	8.0	8.0	8.0
16		8.0	8.0	8.0	8.0	8.0	8.0	8.0	8.0
18			8.0	8.0	8.0	8.0	8.0	8.0	8.0
20				8.0	8.0	8.0	8.0	8.0	8.0
22					8.0	8.0	8.0	8.0	8.0
24					8.0	8.0	8.0	8.0	8.0
26						7.7	7.6	7.5	7.4
28							6.7	6.6	6.5
30								5.8	5.7
32								5.1	5.0
34									4.5

※ The area with “*” shall use 3 t rear counterweight.

Table 3-1 XGC100A Boom single top lifting capacity table (with boom hook) Unit: t

Rear counterweight 34t

Radius (m)	Boom length (m)							
	40	43	46	49	52	55	58	61
9	8.0							
10	8.0	8.0	8.0					
12	8.0	8.0	8.0	8.0	8.0	8.0		
14	8.0	8.0	8.0	8.0	8.0	8.0	8.0	8.0
16	8.0	8.0	8.0	8.0	8.0	8.0	8.0	8.0
18	8.0	8.0	8.0	8.0	8.0	8.0	8.0	8.0
20	8.0	8.0	8.0	8.0	8.0	8.0	8.0	8.0
22	8.0	8.0	8.0	8.0	8.0	8.0	8.0	8.0
24	8.0	8.0	8.0	7.9	7.8	7.6	7.5	7.3
26	7.2	7.1	7.0	6.9	6.7	6.6	6.4	6.2
28	6.4	6.2	6.1	6.0	5.8	5.7	5.5	5.3
30	5.6	5.4	5.3	5.2	5.0	4.9	4.7	4.5
32	4.9	4.8	4.7	4.5	4.4	4.2	4.1	3.9
34	4.3	4.2	4.1	3.9	3.8	3.7	3.5	3.3
36	3.8	3.7	3.6	3.4	3.3	3.2	3.0	2.8
38		3.2	3.1	3.0	2.8	2.7	2.5	2.3
40			2.7	2.6	2.4	2.3	2.1	1.9
42			2.3	2.2	2.0	1.9	1.7	1.6
44				1.9	1.7	1.6	1.4	1.2
46					1.4	1.3	1.1	

5.4 XGC100A Fixed jib lifting capacity table-offset angle 10° (without boom hook)

Table 4-1 100A 7m fixed jib lifting capacity table-offset angle 10° (without boom hook) Unit: t								
Rear counterweight 34t								
Radius (m)	Boom length (m)							
	31	34	37	40	43	46	49	52
9	12.0							
10	12.0	12.0	12.0					
12	12.0	12.0	12.0	12.0	8.0	8.0	8.0	
14	12.0	12.0	12.0	12.0	8.0	8.0	8.0	8.0
16	12.0	12.0	12.0	12.0	8.0	8.0	8.0	8.0
18	12.0	12.0	12.0	12.0	8.0	8.0	8.0	8.0
20	11.3	11.8	12.0	12.0	8.0	8.0	8.0	8.0
22	10.5	11.0	10.9	10.8	8.0	8.0	8.0	8.0
24	9.9	9.8	9.6	9.5	8.0	8.0	8.0	8.0
26	8.9	8.7	8.6	8.5	8.0	8.0	8.0	7.9
28	8.0	7.8	7.7	7.6	7.4	7.3	7.2	7.0
30	7.2	7.0	6.9	6.8	6.6	6.5	6.4	6.2
32	6.5	6.4	6.3	6.1	6.0	5.9	5.7	5.6
34	5.9	5.8	5.7	5.6	5.4	5.3	5.1	5.0
36		5.3	5.2	5.0	4.9	4.8	4.6	4.5
38			4.7	4.6	4.4	4.3	4.2	4.0
40			4.3	4.2	4.0	3.9	3.8	3.6
42				3.8	3.6	3.5	3.4	3.2
44					3.3	3.2	3.1	2.9
46						2.9	2.8	2.6
48							2.5	2.3
50							2.2	2.1
52				26				1.8

Table 4-2 100A 13m fixed jib lifting capacity table-offset angle 10° (without boom hook) Unit: t

Rear counterweight 34t

Radius (m)	Boom length (m)							
	31	34	37	40	43	46	49	52
12	10.2	10.3	8.0					
14	9.7	9.8	8.0	8.0	8.0	8.0		
16	9.2	9.3	8.0	8.0	8.0	8.0	8.0	8.0
18	8.4	8.8	8.0	8.0	8.0	8.0	8.0	8.0
20	7.7	8.0	8.0	8.0	8.0	8.0	8.0	8.0
22	7.1	7.4	8.0	8.0	8.0	8.0	8.0	8.0
24	6.6	6.9	7.6	8.0	8.0	8.0	8.0	8.0
26	6.1	6.4	7.1	7.4	7.7	8.0	8.0	8.0
28	5.7	6.0	6.6	6.9	7.2	7.5	7.4	7.3
30	5.4	5.6	6.2	6.5	6.8	6.8	6.6	6.5
32	5.1	5.3	5.9	6.1	6.2	6.1	6.0	5.8
34	4.8	5.0	5.5	5.8	5.6	5.5	5.4	5.2
36	4.6	4.8	5.3	5.3	5.1	5.0	4.9	4.7
38	4.3	4.6	4.9	4.8	4.6	4.5	4.4	4.2
40	4.2	4.4	4.5	4.4	4.2	4.1	4.0	3.8
42		4.2	4.1	4.0	3.8	3.7	3.6	3.4
44			3.8	3.7	3.5	3.4	3.3	3.1
46				3.4	3.2	3.1	3.0	2.8
48				3.1	2.9	2.8	2.7	2.5
50					2.7	2.5	2.4	2.3
52						2.3	2.2	2.0
54							2.0	1.8
56							1.7	1.6
58				28				1.4

5.5 XGC100A Fixed jib lifting capacity table-offset angle 30° (without boom hook)

Table 5-1 100A 7m fixed jib lifting capacity table-offset angle 30° (without boom hook) Unit: t								
Rear counterweight 34t								
Radius (m)	Boom length (m)							
	31	34	37	40	43	46	49	52
12	10.7	10.9	11.0					
14	10.1	10.3	10.5	10.6	8.0	8.0		
16	9.6	9.8	10.0	10.1	8.0	8.0	8.0	8.0
18	9.2	9.4	9.5	9.7	8.0	8.0	8.0	8.0
20	8.8	9.0	9.2	9.3	8.0	8.0	8.0	8.0
22	8.4	8.6	8.8	9.0	8.0	8.0	8.0	8.0
24	8.1	8.3	8.5	8.7	8.0	8.0	8.0	8.0
26	7.9	8.1	8.3	8.4	8.0	8.0	8.0	8.0
28	7.7	7.8	7.8	7.7	7.6	7.5	7.4	7.2
30	7.3	7.1	7.0	6.9	6.8	6.7	6.6	6.4
32	6.6	6.5	6.4	6.2	6.1	6.0	5.9	5.7
34		5.9	5.8	5.6	5.5	5.4	5.3	5.1
36			5.2	5.1	5.0	4.9	4.8	4.6
38				4.6	4.5	4.4	4.3	4.1
40					4.1	4.0	3.9	3.7
42						3.6	3.5	3.3
44							3.1	3.0
46								2.7
48								2.4

Table 5-2 100A 13m fixed jib lifting capacity table-offset angle 30° (without boom hook) Unit: t

Rear counterweight 34t

Radius (m)	Boom length (m)							
	31	34	37	40	43	46	49	52
16	6.1	6.2	6.3					
18	5.8	5.9	6.0	6.4	6.4	6.5	6.6	
20	5.4	5.6	5.7	6.0	6.1	6.2	6.3	6.4
22	5.2	5.3	5.4	5.7	5.8	5.9	6.0	6.1
24	4.9	5.0	5.1	5.5	5.6	5.7	5.8	5.8
26	4.7	4.8	4.9	5.2	5.3	5.4	5.5	5.6
28	4.5	4.6	4.7	5.0	5.1	5.2	5.3	5.4
30	4.3	4.5	4.6	4.8	4.9	5.0	5.1	5.2
32	4.2	4.3	4.4	4.7	4.8	4.9	5.0	5.0
34	4.1	4.2	4.3	4.5	4.6	4.7	4.8	4.9
36	4.0	4.1	4.1	4.4	4.5	4.6	4.7	4.7
38		4.0	4.0	4.3	4.4	4.4	4.5	4.5
40		3.9	3.9	4.2	4.2	4.3	4.2	4.0
42			3.9	4.1	4.0	3.9	3.8	3.6
44				3.8	3.6	3.5	3.4	3.3
46					3.3	3.2	3.1	3.0
48						2.9	2.8	2.7
50							2.5	2.4
52								2.1
54								1.9

Table 5-3 100A 19m fixed jib lifting capacity table-offset angle 30° (without boom hook) Unit: t

Rear counterweight 34t

Radius (m)	Boom length (m)							
	31	34	37	40	43	46	49	52
20	3.8	3.8	3.8	3.9				
22	3.6	3.7	3.7	3.7	3.8	3.8	3.8	3.8
24	3.5	3.5	3.6	3.6	3.6	3.7	3.7	3.7
26	3.3	3.4	3.5	3.5	3.5	3.6	3.6	3.6
28	3.2	3.3	3.3	3.4	3.4	3.5	3.5	3.5
30	3.1	3.2	3.2	3.3	3.3	3.4	3.4	3.4
32	3.0	3.1	3.1	3.2	3.2	3.3	3.3	3.3
34	2.9	3.0	3.0	3.1	3.2	3.2	3.2	3.3
36	2.8	2.9	3.0	3.0	3.1	3.1	3.2	3.2
38	2.7	2.8	2.9	2.9	3.0	3.0	3.1	3.1
40	2.6	2.7	2.8	2.8	2.9	3.0	3.0	3.1
42	2.6	2.7	2.7	2.8	2.8	2.9	2.9	3.0
44		2.6	2.7	2.7	2.8	2.8	2.9	2.9
46		2.5	2.6	2.7	2.7	2.8	2.8	2.9
48			2.5	2.6	2.6	2.7	2.7	2.8
50				2.5	2.6	2.6	2.7	2.6
52					2.5	2.6	2.5	2.3
54						2.3	2.2	2.1
56							2.0	1.9
58								1.7

VI. Parts transportation and transport planning

6.1 Parts transportation

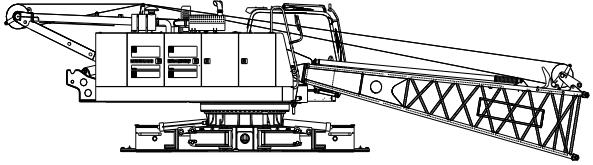
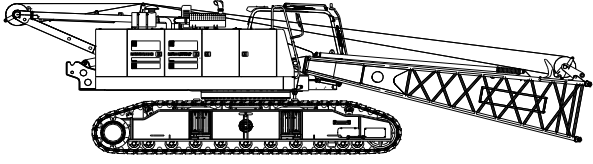
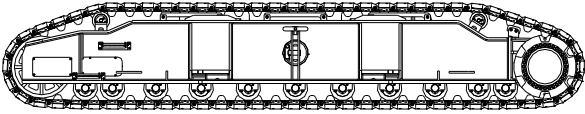
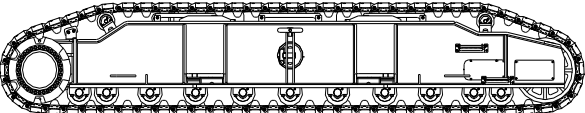
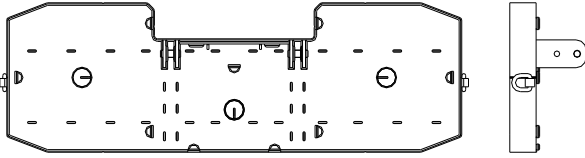
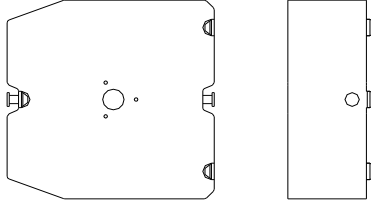
No.	Component Name			L (m)	W (m)	H (m)	W (t)	Note
1	Basic crane transport plan I	Qty.	1	13.04	3.4	3.04	24.1	Include luffing pulley block, boom butt and connecting bar, hydraulic oil about 400L, fuel oil about 50L.
								
2	Basic crane transport plan II	Qty.	1	13.04	3.49	3.49	44.7	Include left and right track frames, luffing pulley block, boom butt and connecting bar, hydraulic oil about 400L, fuel oil about 50L.
								
3	Left track frame	Qty.	1	6.85	1.15	1.23	10.3	
								
4	Right track frame	Qty.	1	6.85	1.15	1.23	10.3	
								
5	Counterweight tray	Qty.	1	4.64	1.45	0.75	7.0	
								
6	Left and right counterweight block	Qty.	6	1.45	1.45	0.59	3.5	
								
7	Counterweight block I	Qty.	2	1.5	0.85	0.79	3.0	

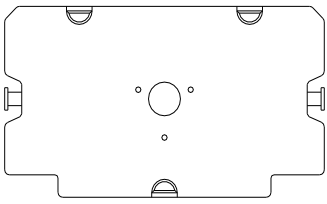
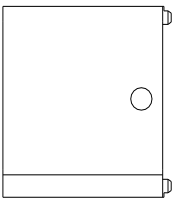
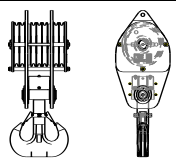
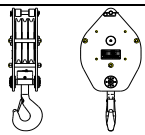
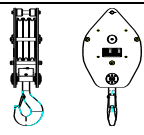
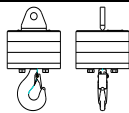
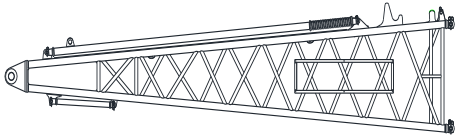
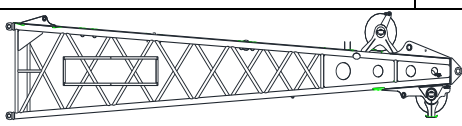
No.	Component Name	L (m)	W (m)	H (m)	W (t)	Note		
								
								
8	100t capacity hook block	Qty.	1	0.705	0.63	1.65	0.96	
								
9	55t capacity hook block	Qty.	1	0.54	0.63	1.5	0.62	
								
10	35t capacity hook block	Qty.	1	0.34	0.63	1.35	0.46	
								
11	8t capacity hook block	Qty.	1	0.32	0.32	0.75	0.25	
								
12	6.5m boom butt	Qty.	1	6.67	1.69	1.57	1.25	Include boom butt, boom backstop, connecting bar, use transported without basic crane
								
13	6.5m boom top	Qty.	1	7.10	1.69	1.60	1.30	
								
14	9m boom insert	Qty.	4	9.12	1.69	1.42	0.90	

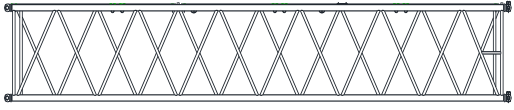
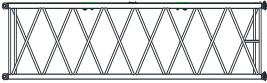
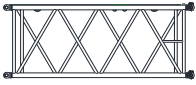
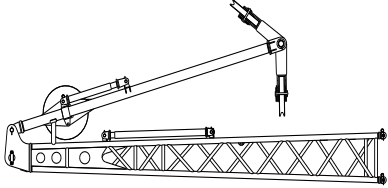
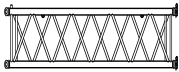
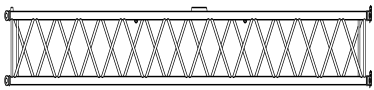
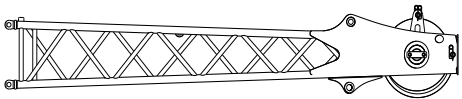
No.	Component Name	L (m)	W (m)	H (m)	W (t)	Note		
								
15	6m boom insert	Qty.	1	6.12	1.69	1.42	0.65	
								
16	3m boom insert	Qty.	2	3.12	1.69	1.42	0.40 5	
								
17	Fixed jib butt (include strut and guy cable)	Qty.	1	4.105	0.70	1.65 3	0.5	Include fixed jib butt, fixed jib strut, front backstop bar assembly, rear backstop bar assembly, front guy cable, rear guy cable.
								
18	3m fixed jib insert	Qty.	2	3.06	0.655	0.48 5	0.10 4	
								
19	6m fixed jib insert	Qty.	1	6.06	0.655	0.48 5	0.19 2	
								
20	Fixed jib top	Qty.	1	3.33	0.655	0.63 3	0.22	
								
21	Fixed jib top	Qty.	1	1.40	0.625	0.56	0.12	

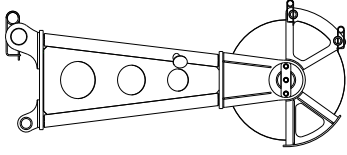
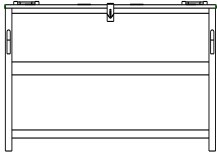
No.	Component Name		L (m)	W (m)	H (m)	W (t)	Note
					2		
22	Small parts box	Qty. 1	1.26	1.11	0.7	1.0	Include filters, tool box, first aid box, hoisting jack, lever type information bag, wedge sleeve, counterweight and other small electric parts.
							

Note: The weight and size of the main components are the theoretical design values, which may be slightly different due to manufacturing errors.

6.2 Transport planning

XGC100A transport vehicles

Vehicle 1

Part	Qty.	Weight (t)
■ Basic machine	1	24.1
■ 100t hook	1	0.96
■ 35t hook	1	0.46
■ 8t hook	1	0.25
■ Counterweight block I	1	3.00
■ 6m jib insert	1	0.38
■ Small parts box	1	1.00

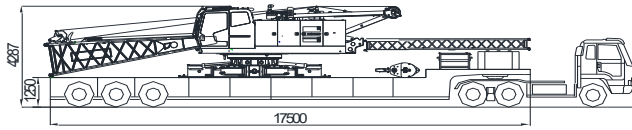

Total weight 29.96

Vehicle 2

Part	Qty.	Weight (t)
■ Left track frame	1	10.30
■ Right track frame	1	10.30
■ 3m boom insert	2	0.81
■ 6m boom insert	1	0.65
■ Counterweight block	2	7.00
■ Single top	1	0.12
■ 55t hook	1	0.62

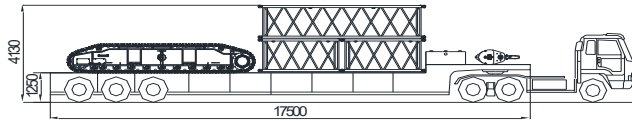

Total weight 29.8

Vehicle 3

Part	Qty.	Weight (t)
■ 9m boom insert	4	3.60
■ Counterweight tray	1	7.00
■ Counterweight block	4	14.00
■ Counterweight block I	1	3.00
■ Boom top	1	1.30
■ Jib butt	1	0.50
■ Jib top	1	0.22
■ 3m jib insert	2	0.21

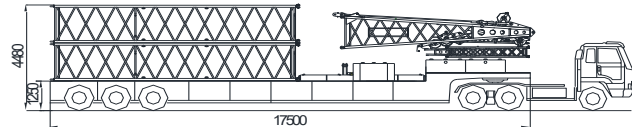

Total weight 29.82

Note:

- 1) The arrangement of the parts on transport vehicles are only one of the method for placement, they can be placed in a more reasonable way according to actual situation;
- 2) The transport vehicle refers to the vehicle of 17.5m, with rated load not exceed 30t.

Note: This transport plan is only suit for the crane with full working conditions, the data in the figure are theoretical values; please take actual size as standard. This plan is for reference only!

Special notes:

- ★ This technical specification is for reference only, please prevail to the actual product.
- ★ The technical specification will be updated regularly according to the change of the product. The updated content will be added in the new version without prior notice. After the update, some of the function, configuration and technical parameters of the crane may be slightly different.
- ★ Due to the instability of the real environment and other reasons, the actual value of some parameters may be different from the value provided in this document. If there is any doubt,

please refer to the final explanation of our company.